

SECTION **SE**
SEAT

A
B
C
D
E
F
G
H
SE
J
K
L
M

CONTENTS

PRECAUTIONS 3	Schematic / For A/T Models 15
Precautions for Supplemental Restraint System (SRS) "AIR BAG" and "SEAT BELT PRE-TENSIONER" 3	Wiring Diagram–AUT/DP– / For A/T Models 16
Service Notice 3	Schematic / For M/T Models 22
Precautions for Work 3	Wiring Diagram–SEAT– / For M/T Models 23
PREPARATION 4	Terminals and Reference Values for Driver Seat Control Unit 29
Special Service Tools 4	On Board Diagnosis 31
Commercial Service Tools 4	HOW TO PERFORM SELF-DIAGNOSIS 32
SQUEAK AND RATTLE TROUBLE DIAGNOSES 5	MALFUNCTION CODE TABLE 33
Work Flow 5	Trouble Diagnosis 34
CUSTOMER INTERVIEW 5	WORK FLOW 34
DUPLICATE THE NOISE AND TEST DRIVE 6	PRELIMINARY CHECK 35
CHECK RELATED SERVICE BULLETINS 6	SYMPTOM CHART 36
LOCATE THE NOISE AND IDENTIFY THE ROOT CAUSE 6	DIAGNOSTIC PROCEDURE 1 38
REPAIR THE CAUSE 6	DIAGNOSTIC PROCEDURE 2 39
CONFIRM THE REPAIR 7	DIAGNOSTIC PROCEDURE 3 40
Generic Squeak and Rattle Troubleshooting 7	DIAGNOSTIC PROCEDURE 4 41
INSTRUMENT PANEL 7	DIAGNOSTIC PROCEDURE 5 42
CENTER CONSOLE 7	DIAGNOSTIC PROCEDURE 6 43
DOORS 7	DIAGNOSTIC PROCEDURE 7 44
TRUNK 8	DIAGNOSTIC PROCEDURE 8 45
SUNROOF/HEADLINING 8	DIAGNOSTIC PROCEDURE 9 46
SEATS 8	DIAGNOSTIC PROCEDURE 10 47
UNDERHOOD 8	DIAGNOSTIC PROCEDURE 11 47
Diagnostic Worksheet 9	DIAGNOSTIC PROCEDURE 12 48
AUTOMATIC DRIVE POSITIONER 11	DIAGNOSTIC PROCEDURE 13 52
System Description 11	DIAGNOSTIC PROCEDURE 14 52
OPERATIVE CONDITION 11	POWER SEAT 53
CONDITIONS INHIBITING AUTOMATIC OPERATION 11	Wiring Diagram–SEAT– for Driver Seat 53
FAIL-SAFE SYSTEM 11	Wiring Diagram–SEAT– for Passenger Seat 55
INITIALIZATION 11	HEATED SEAT 56
MEMORY AUTOMATIC SET 12	Description 56
AUTOMATIC EXITING SETTING (A/T MODELS) 13	Schematic 57
AUTOMATIC SET RETURN (A/T MODELS) 13	Wiring Diagram – HSEAT – / For A/T Models 58
Component Parts and Harness Connector Location. 14	Wiring Diagram – HSEAT – / For M/T Models 61
	FRONT SEAT 64
	Removal and Installation 64
	REMOVAL 67

INSTALLATION	67	SEAT)	69
Disassembly and Assembly	68	SEAT CUSHION TRIM AND PAD (MANUAL	
SEATBACK TRIM AND PAD	68	SEAT)	70
REMOVAL OF SEATBACK ASSEMBLY	69	REAR SEAT	71
INSTALLATION OF SEATBACK ASSEMBLY	69	Removal and Installation	71
SEAT CUSHION TRIM AND PAD (POWER		REMOVAL	73
		INSTALLATION	73

PRECAUTIONS

PRECAUTIONS

PFP:00001

Precautions for Supplemental Restraint System (SRS) “AIR BAG” and “SEAT BELT PRE-TENSIONER”

AIS000AX

The Supplemental Restraint System such as “AIR BAG” and “SEAT BELT PRE-TENSIONER”, used along with a front seat belt, helps to reduce the risk or severity of injury to the driver and front passenger for certain types of collision. This system includes seat belt switch inputs and dual stage front air bag modules. The SRS system uses the seat belt switches to determine the front air bag deployment, and may only deploy one front air bag, depending on the severity of a collision and whether the front occupants are belted or unbelted. Information necessary to service the system safely is included in the SRS and SB section of this Service Manual.

WARNING:

- To avoid rendering the SRS inoperative, which could increase the risk of personal injury or death in the event of a collision which would result in air bag inflation, all maintenance must be performed by an authorized NISSAN/INFINITI dealer.
- Improper maintenance, including incorrect removal and installation of the SRS, can lead to personal injury caused by unintentional activation of the system. For removal of Spiral Cable and Air Bag Module, see the SRS section.
- Do not use electrical test equipment on any circuit related to the SRS unless instructed to in this Service Manual. SRS wiring harnesses can be identified by yellow and/or orange harnesses or harness connectors.

Service Notice

AIS0007W

- When removing or installing various parts, place a cloth or padding onto the vehicle body to prevent scratches.
- Handle trim, molding, instruments, grille, etc. carefully during removing or installing. Be careful not to oil or damage them.
- Apply sealing compound where necessary when installing parts.
- When applying sealing compound, be careful that the sealing compound does not protrude from parts.
- When replacing any metal parts (for example body outer panel, members, etc.), be sure to take rust prevention measures.

Precautions for Work

AIS000AY

- When removing or disassembling each component, be careful not to damage or deform it. If a component may be subject to interference, be sure to protect it with a cloth.
- When removing (disengaging) components with a screwdriver or similar tool, be sure to wrap the component with a cloth or vinyl tape to protect it.
- Protect the removed parts with a cloth and keep them.
- Replace a deformed or damaged clip.
- If a part is specified as a non-reusable part, always replace it with new one.
- Be sure to tighten bolts and nuts securely to the specified torque.
- After re-installation is completed, be sure to check that each part works normally.
- Follow the steps below to clean components.
 - Water soluble foul: Dip a soft cloth into lukewarm water, and wring the water out of the cloth to wipe the fouled area.
Then rub with a soft and dry cloth.
 - Oily foul: Dip a soft cloth into lukewarm water with mild detergent (concentration: within 2 to 3%), and wipe the fouled area.
Then dip a cloth into fresh water, and wring the water out of the cloth to wipe the detergent off. Then rub with a soft and dry cloth.
- Do not use organic solvent such as thinner, benzene, alcohol, and gasoline.
- For genuine leather seats, use a genuine leather seat cleaner.

PREPARATION

PREPARATION

PFP:00002

Special Service Tools

AIS00080

The actual shapes of Kent-Moore tools may differ from those of special service tools illustrated here.

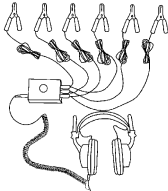
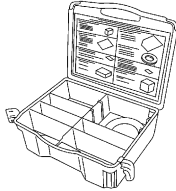
Tool number (Kent-Moore No.) Tool name	Description
(J39570) Chassis ear  <p style="text-align: right; margin-right: 20px;">SIIA0993E</p>	Locating the noise
(J43980) NISSAN Squeak and Rattle Kit  <p style="text-align: right; margin-right: 20px;">SIIA0994E</p>	Repairing the cause of noise

Commercial Service Tools

AIS00081

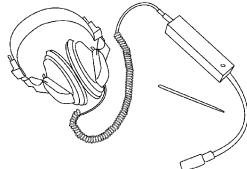
Tool name	Description
Engine ear  <p style="text-align: right; margin-right: 20px;">SIIA0995E</p>	Locating the noise

SQUEAK AND RATTLE TROUBLE DIAGNOSES

SQUEAK AND RATTLE TROUBLE DIAGNOSES

PFP:00000

Work Flow

AIS00082

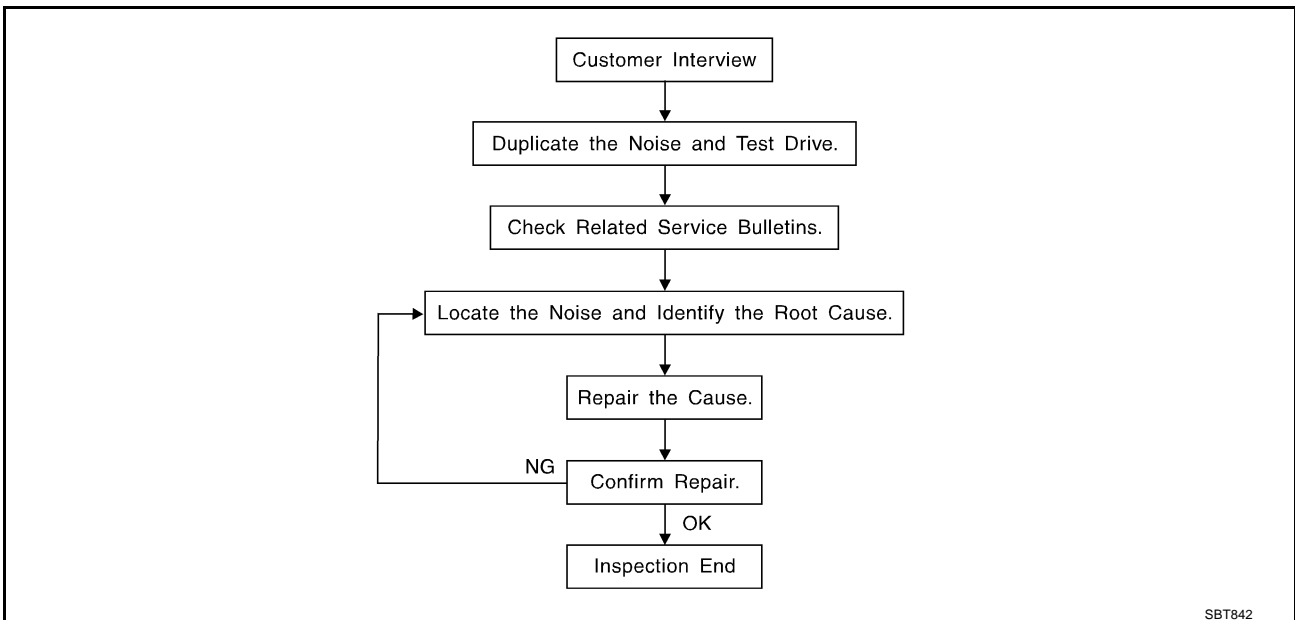

CUSTOMER INTERVIEW

Interview the customer if possible, to determine the conditions that exist when the noise occurs. Use the Diagnostic Worksheet during the interview to document the facts and conditions when the noise occurs and any customer's comments; refer to [SE-9, "Diagnostic Worksheet"](#). This information is necessary to duplicate the conditions that exist when the noise occurs.

- The customer may not be able to provide a detailed description or the location of the noise. Attempt to obtain all the facts and conditions that exist when the noise occurs (or does not occur).
- If there is more than one noise in the vehicle, be sure to diagnose and repair the noise that the customer is concerned about. This can be accomplished by test driving the vehicle with the customer.
- After identifying the type of noise, isolate the noise in terms of its characteristics. The noise characteristics are provided so the customer, service adviser and technician are all speaking the same language when defining the noise.
- Squeak—(Like tennis shoes on a clean floor)
Squeak characteristics include the light contact/fast movement/brought on by road conditions/hard surfaces=higher pitch noise/softer surfaces=lower pitch noises/edge to surface=chirping
- Creak—(Like walking on an old wooden floor)
Creak characteristics include firm contact/slow movement/twisting with a rotational movement/pitch dependent on materials/often brought on by activity.
- Rattle—(Like shaking a baby rattle)
Rattle characteristics include the fast repeated contact/vibration or similar movement/loose parts/missing clip or fastener/incorrect clearance.
- Knock—(Like a knock on a door)
Knock characteristics include hollow sounding/sometimes repeating/often brought on by driver action.
- Tick—(Like a clock second hand)
Tick characteristics include gentle contacting of light materials/loose components/can be caused by driver action or road conditions.
- Thump—(Heavy, muffled knock noise)
Thump characteristics include softer knock/dead sound often brought on by activity.
- Buzz—(Like a bumble bee)
Buzz characteristics include high frequency rattle/firm contact.
- Often the degree of acceptable noise level will vary depending upon the person. A noise that you may judge as acceptable may be very irritating to the customer.
- Weather conditions, especially humidity and temperature, may have a great effect on noise level.

SQUEAK AND RATTLE TROUBLE DIAGNOSES

DUPLICATE THE NOISE AND TEST DRIVE

If possible, drive the vehicle with the customer until the noise is duplicated. Note any additional information on the Diagnostic Worksheet regarding the conditions or location of the noise. This information can be used to duplicate the same conditions when you confirm the repair.

If the noise can be duplicated easily during the test drive, to help identify the source of the noise, try to duplicate the noise with the vehicle stopped by doing one or all of the following:

- 1) Close a door.
 - 2) Tap or push/pull around the area where the noise appears to be coming from.
 - 3) Rev the engine.
 - 4) Use a floor jack to recreate vehicle "twist".
 - 5) At idle, apply engine load (electrical load, half-clutch on M/T model, drive position on A/T model).
 - 6) Raise the vehicle on a hoist and hit a tire with a rubber hammer.
- Drive the vehicle and attempt to duplicate the conditions the customer states exist when the noise occurs.
 - If it is difficult to duplicate the noise, drive the vehicle slowly on an undulating or rough road to stress the vehicle body.

CHECK RELATED SERVICE BULLETINS

After verifying the customer concern or symptom, check ASIST for Technical Service Bulletins (TSBs) related to that concern or symptom.

If a TSB relates to the symptom, follow the procedure to repair the noise.

LOCATE THE NOISE AND IDENTIFY THE ROOT CAUSE

1. Narrow down the noise to a general area. To help pinpoint the source of the noise, use a listening tool (Chassis Ear: J39570, Engine Ear and mechanics stethoscope).
2. Narrow down the noise to a more specific area and identify the cause of the noise by:
 - removing the components in the area that you suspect the noise is coming from.
Do not use too much force when removing clips and fasteners, otherwise clips and fastener can be broken or lost during the repair, resulting in the creation of new noise.
 - tapping or pushing/pulling the component that you suspect is causing the noise.
Do not tap or push/pull the component with excessive force, otherwise the noise will be eliminated only temporarily.
 - feeling for a vibration with your hand by touching the component(s) that you suspect is (are) causing the noise.
 - placing a piece of paper between components that you suspect are causing the noise.
 - looking for loose components and contact marks.
Refer to [SE-7, "Generic Squeak and Rattle Troubleshooting"](#) .

REPAIR THE CAUSE

- If the cause is a loose component, tighten the component securely.
- If the cause is insufficient clearance between components:
 - separate components by repositioning or loosening and retightening the component, if possible.
 - insulate components with a suitable insulator such as urethane pads, foam blocks, felt cloth tape or urethane tape. A Nissan Squeak and Rattle Kit (J43980) is available through your authorized Nissan Parts Department.

CAUTION:

Do not use excessive force as many components are constructed of plastic and may be damaged.

Always check with the Parts Department for the latest parts information.

The following materials are contained in the Nissan Squeak and Rattle Kit (J43980). Each item can be ordered separately as needed.

URETHANE PADS [1.5 mm (0.059 in) thick]

Insulates connectors, harness, etc.

76268-9E005: 100 × 135 mm (3.94 × 5.31 in)/76884-71L01: 60 × 85 mm (2.36 × 3.35 in)/76884-71L02: 15 × 25 mm (0.59 × 0.98 in)

INSULATOR (Foam blocks)

Insulates components from contact. Can be used to fill space behind a panel.

73982-9E000: 45 mm (1.77 in) thick, 50 × 50 mm (1.97 × 1.97 in)/73982-50Y00: 10 mm (0.39 in) thick, 50 × 50 mm (1.97 × 1.97 in)

SQUEAK AND RATTLE TROUBLE DIAGNOSES

INSULATOR (Light foam block)

80845-71L00: 30 mm (1.18 in) thick, 30 × 50 mm (1.18 × 1.97 in)

FELT CLOTHTAPE

Used to insulate where movement does not occur. Ideal for instrument panel applications.

68370-4B000: 15 × 25 mm (0.59 × 0.98 in) pad/68239-13E00: 5 mm (0.20 in) wide tape roll

The following materials, not found in the kit, can also be used to repair squeaks and rattles.

UHMW (TEFLON) TAPE

Insulates where slight movement is present. Ideal for instrument panel applications.

SILICONE GREASE

Used in place of UHMW tape that will be visible or not fit.

Note: Will only last a few months.

SILICONE SPRAY

Use when grease cannot be applied.

DUCT TAPE

Use to eliminate movement.

CONFIRM THE REPAIR

Confirm that the cause of a noise is repaired by test driving the vehicle. Operate the vehicle under the same conditions as when the noise originally occurred. Refer to the notes on the Diagnostic Worksheet.

Generic Squeak and Rattle Troubleshooting

AIS00083

Refer to Table of Contents for specific component removal and installation information.

INSTRUMENT PANEL

Most incidents are caused by contact and movement between:

1. The cluster lid A and instrument panel
2. Acrylic lens and combination meter housing
3. Instrument panel to front pillar garnish
4. Instrument panel to windshield
5. Instrument panel mounting pins
6. Wiring harnesses behind the combination meter
7. A/C defroster duct and duct joint

These incidents can usually be located by tapping or moving the components to duplicate the noise or by pressing on the components while driving to stop the noise. Most of these incidents can be repaired by applying felt cloth tape or silicon spray (in hard to reach areas). Urethane pads can be used to insulate wiring harness.

CAUTION:

Do not use silicone spray to isolate a squeak or rattle. If you saturate the area with silicone, you will not be able to recheck the repair.

CENTER CONSOLE

Components to pay attention to include:

1. Shifter assembly cover to finisher
2. A/C control unit and cluster lid C
3. Wiring harnesses behind audio and A/C control unit

The instrument panel repair and isolation procedures also apply to the center console.

DOORS

Pay attention to the:

1. Finisher and inner panel making a slapping noise
2. Inside handle escutcheon to door finisher
3. Wiring harnesses tapping
4. Door striker out of alignment causing a popping noise on starts and stops

Tapping or moving the components or pressing on them while driving to duplicate the conditions can isolate many of these incidents. You can usually insulate the areas with felt cloth tape or insulator foam blocks from the Nissan Squeak and Rattle Kit (J43980) to repair the noise.

SQUEAK AND RATTLE TROUBLE DIAGNOSES

TRUNK

Trunk noises are often caused by a loose jack or loose items put into the trunk by the owner. In addition look for:

1. Trunk lid dumpers out of adjustment
2. Trunk lid striker out of adjustment
3. The trunk lid torsion bars knocking together
4. A loose license plate or bracket

Most of these incidents can be repaired by adjusting, securing or insulating the item(s) or component(s) causing the noise.

SUNROOF/HEADLINING

Noises in the sunroof/headlining area can often be traced to one of the following:

1. Sunroof lid, rail, linkage or seals making a rattle or light knocking noise
2. Sun visor shaft shaking in the holder
3. Front or rear windshield touching headlining and squeaking

Again, pressing on the components to stop the noise while duplicating the conditions can isolate most of these incidents. Repairs usually consist of insulating with felt cloth tape.

SEATS

When isolating seat noise it's important to note the position the seat is in and the load placed on the seat when the noise is present. These conditions should be duplicated when verifying and isolating the cause of the noise.

Cause of seat noise include:

1. Headrest rods and holder
2. A squeak between the seat pad cushion and frame
3. The rear seatback lock and bracket

These noises can be isolated by moving or pressing on the suspected components while duplicating the conditions under which the noise occurs. Most of these incidents can be repaired by repositioning the component or applying urethane tape to the contact area.

UNDERHOOD

Some interior noise may be caused by components under the hood or on the engine wall. The noise is then transmitted into the passenger compartment.

Causes of transmitted underhood noise include:

1. Any component mounted to the engine wall
2. Components that pass through the engine wall
3. Engine wall mounts and connectors
4. Loose radiator mounting pins
5. Hood bumpers out of adjustment
6. Hood striker out of adjustment

These noises can be difficult to isolate since they cannot be reached from the interior of the vehicle. The best method is to secure, move or insulate one component at a time and test drive the vehicle. Also, engine RPM or load can be changed to isolate the noise. Repairs can usually be made by moving, adjusting, securing, or insulating the component causing the noise.

SQUEAK AND RATTLE TROUBLE DIAGNOSES

Diagnostic Worksheet

AI500084



SQUEAK & RATTLE DIAGNOSTIC WORKSHEET

Dear Infiniti Customer:

We are concerned about your satisfaction with your Infiniti vehicle. Repairing a squeak or rattle sometimes can be very difficult. To help us fix your Infiniti right the first time, please take a moment to note the area of the vehicle where the squeak or rattle occurs and under what conditions. You may be asked to take a test drive with a service advisor or technician to ensure we confirm the noise you are hearing.

I. WHERE DOES THE NOISE COME FROM? (circle the area of the vehicle)

The illustrations are for reference only, and may not reflect the actual configuration of your vehicle.

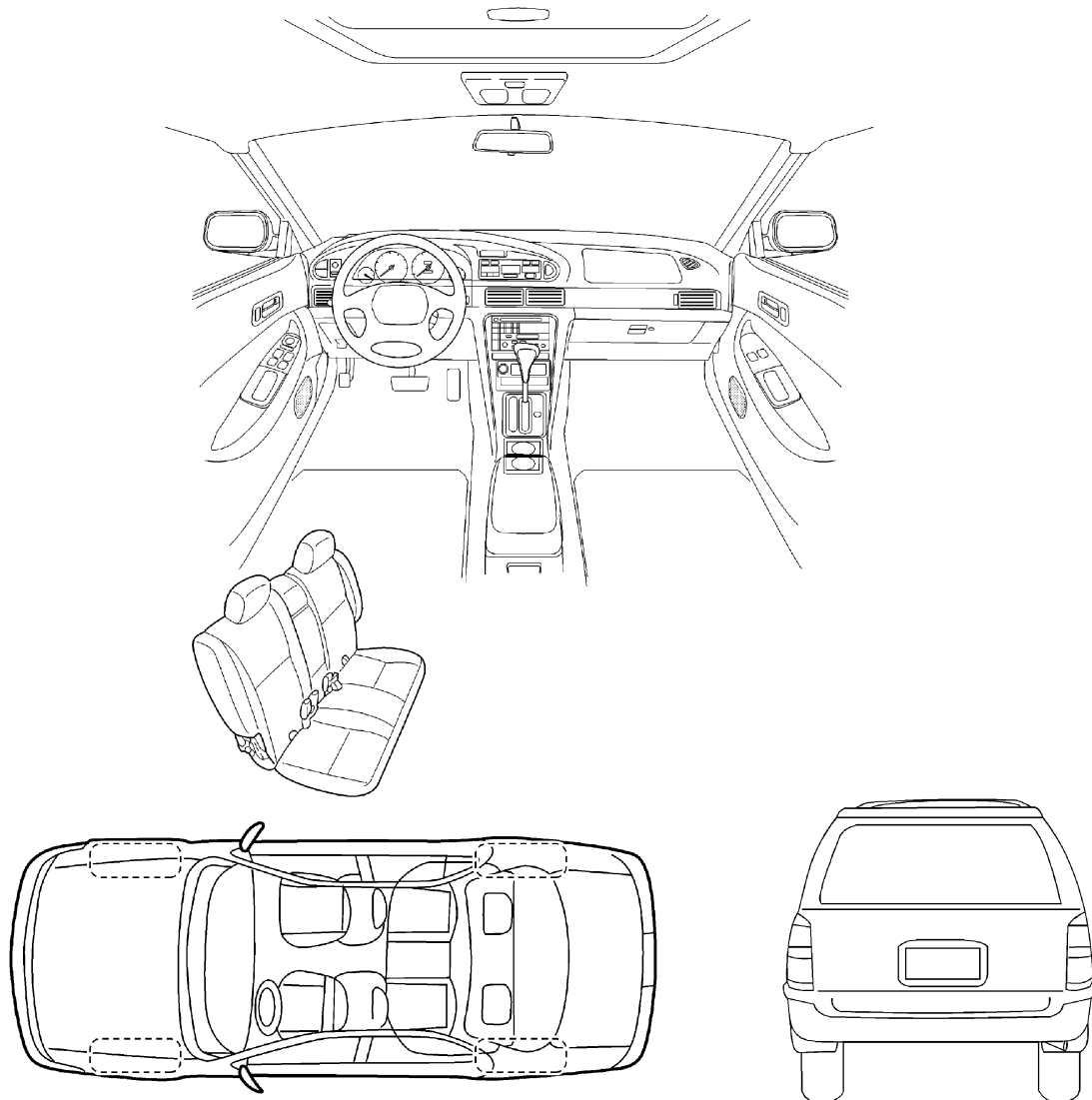

Continue to the back of the worksheet and briefly describe the location of the noise or rattle. In addition, please indicate the conditions which are present when the noise occurs.

SBT860

A
B
C
D
E
F
G
H
SE
J
K
L
M

SQUEAK AND RATTLE TROUBLE DIAGNOSES

SQUEAK & RATTLE DIAGNOSTIC WORKSHEET- page 2

Briefly describe the location where the noise occurs:

II. WHEN DOES IT OCCUR? (check the boxes that apply)

- | | |
|--|---|
| <input type="checkbox"/> anytime | <input type="checkbox"/> after sitting out in the sun |
| <input type="checkbox"/> 1 st time in the morning | <input type="checkbox"/> when it is raining or wet |
| <input type="checkbox"/> only when it is cold outside | <input type="checkbox"/> dry or dusty conditions |
| <input type="checkbox"/> only when it is hot outside | <input type="checkbox"/> other: _____ |

III. WHEN DRIVING:

- through driveways
- over rough roads
- over speed bumps
- only at about ____ mph
- on acceleration
- coming to a stop
- on turns : left, right or either (circle)
- with passengers or cargo
- other: _____
- after driving ____ miles or ____ minutes

IV. WHAT TYPE OF NOISE?

- squeak (like tennis shoes on a clean floor)
- creak (like walking on an old wooden floor)
- rattle (like shaking a baby rattle)
- knock (like a knock on a door)
- tick (like a clock second hand)
- thump (heavy, muffled knock noise)
- buzz (like a bumble bee)

TO BE COMPLETED BY DEALERSHIP PERSONNEL

Test Drive Notes:

	YES	NO	Initials of person performing
Vehicle test driven with customer	<input type="checkbox"/>	<input type="checkbox"/>	_____
- Noise verified on test drive	<input type="checkbox"/>	<input type="checkbox"/>	_____
- Noise source located and repaired	<input type="checkbox"/>	<input type="checkbox"/>	_____
- Follow up test drive performed to confirm repair	<input type="checkbox"/>	<input type="checkbox"/>	_____

VIN: _____ Customer Name: _____

W.O. #: _____ Date: _____

This form must be attached to Work Order

SBT844

AUTOMATIC DRIVE POSITIONER

AUTOMATIC DRIVE POSITIONER

PPF:28491

System Description OPERATIVE CONDITION

AIS000AM

The drive position can be set in 2 ways, manually and automatically.

Manual Operation

The driver's seat can be adjusted for sliding, reclining, front cushion height and rear cushion height with the LH power seat switches. The manual operation can be adjusted with the ignition key in any position.

Automatic Operation

The driver's seat is adjusted to the proper positions for the driver automatically, in 3 different ways: MEMORY AUTOMATIC SET, AUTOMATIC EXITING SETTING and AUTOMATIC SET RETURN. (Automatic Drive Positioner = ADP)

CONDITIONS INHIBITING AUTOMATIC OPERATION

Automatic memory setting operation are suspended under any of the following conditions:

1. When vehicle speed is more than 7 km/h (4 MPH).
2. When driver's side power seat switch is turned ON.
3. When any two of the switches (set switch and memory switches 1 and 2) are turned ON.
4. When cancel switch is turned ON.
5. When selector lever is in any position other than "P" (A/T models) or parking brake is released (M/T models).
6. When ignition switch is turned to "START" position.
[Operation resumes when ignition switch is returned to "ON" (A/T models)]
7. When detention switch malfunction is detected (A/T models).
Detention switch malfunction is sensed when detention switch remains OFF for at least 2 seconds at a vehicle speed of higher than 7 km/h (4 MPH).
8. When parking brake switch malfunction is detected (M/T models).
Parking brake switch malfunction is sensed when parking brake switch remains ON for at least 2 seconds at a vehicle speed of higher than 7 km/h (4 MPH).

FAIL-SAFE SYSTEM

Output Malfunction

When the ignition switch is in the ON position, if any of the parts (indicated in the following chart) move more than the specified amount within a period "T1" when no "ON" input is sent from any of the switches (indicated in the following chart), or an output from the automatic drive positioner is not produced, an output malfunction is sensed. Motor operation will be suspended automatically, and all automatic operations will be ineffective. (In this case, the motor will not operate manually.)

OPERATED PORTION	T1	Allowable measurement
Seat sliding	Approx. 2.5 sec.	Within 6 mm (0.24 in)
Seat reclining	Approx. 2.5 sec.	Change angle within 2.22°

Canceling Fail-safe Mode

When moving selector lever back to "P" position after having moved it to any P position except "P" (A/T models) or applying parking brake after having released it (M/T models), fail-safe operation will be canceled.

INITIALIZATION

After reconnecting battery cable, perform initialization procedure A or B. If initialization has not been performed, automatic drive positioner will not operate.

PROCEDURE A

1. Insert key in the ignition key cylinder. (Ignition switch is in "OFF" position.)
2. Open → close → open driver side door. (Do not perform with the door switch operation.)
3. End

PROCEDURE B

1. Drive the vehicle at more than 25 km/h (16 MPH).
2. End

AUTOMATIC DRIVE POSITIONER

MEMORY AUTOMATIC SET

Two drive positions can be retained in the memory. Press memory switch to set driver's seat to preset position.

PROCEDURE FOR STORING MEMORY

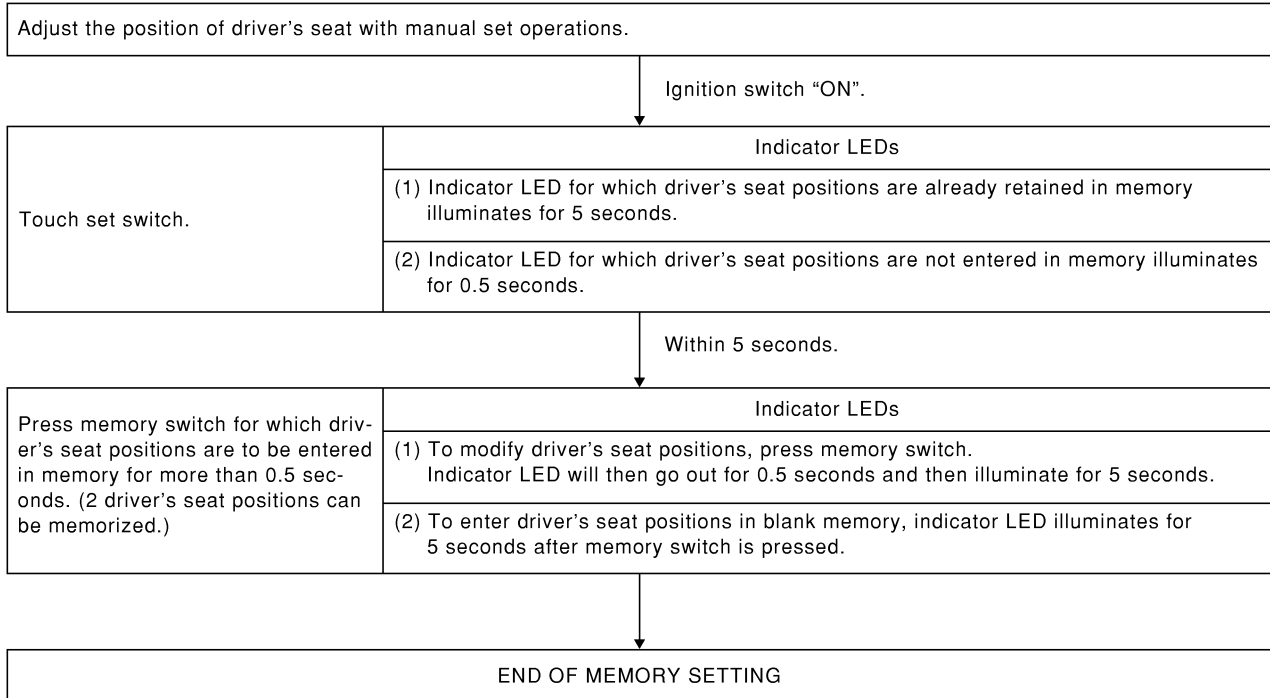

SEL592W

NOTE:

- When memory switch for which driver's seat positions are already retained in memory is pressed, new seat positions will be retained in memory in place of the previously set positions.
- Drive position is erased from the memory when battery cable is disconnected more than 30 seconds. After connecting battery cable, perform initialization procedures. Refer to [SE-11, "INITIALIZATION"](#).

SELECTING THE MEMORIZED POSITION

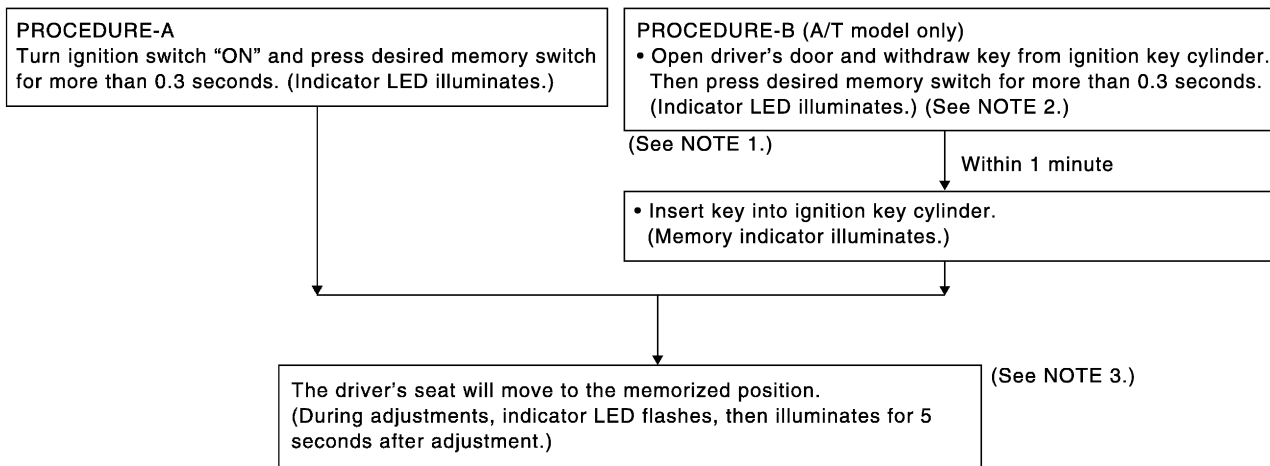

SEL425Y

NOTE:

1. Do not keep cancel switch pressed as it will not operate.
2. Automatic exiting setting will be performed.

AUTOMATIC DRIVE POSITIONER

3. The driver's seat position (see the following Table) operates in the order of priority.

The order of priority	Operated portion
1	Seat sliding
2	Seat reclining
3	Seat front lifting
4	Seat rear lifting

AUTOMATIC EXITING SETTING (A/T MODELS)

“Exiting” positions: Driver's seat... Slides about 40 mm (1.57 in) rear from normal sitting position.

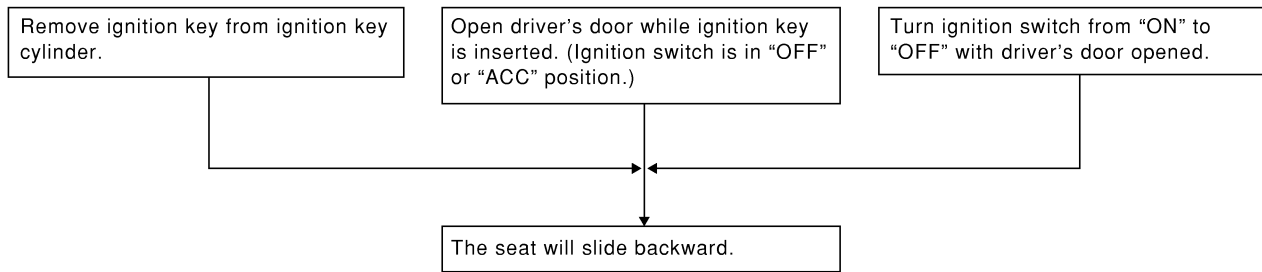

SEL594W

AUTOMATIC SET RETURN (A/T MODELS)

With driver's seat set to the “exiting” position, operating one of the following procedures moves it to the position previously retained in memory.

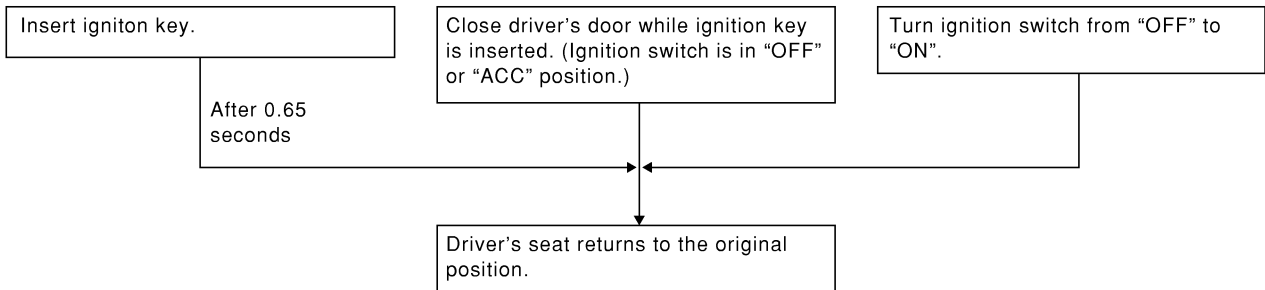

SEL595W

AUTOMATIC DRIVE POSITIONER

Component Parts and Harness Connector Location

AIS000AN

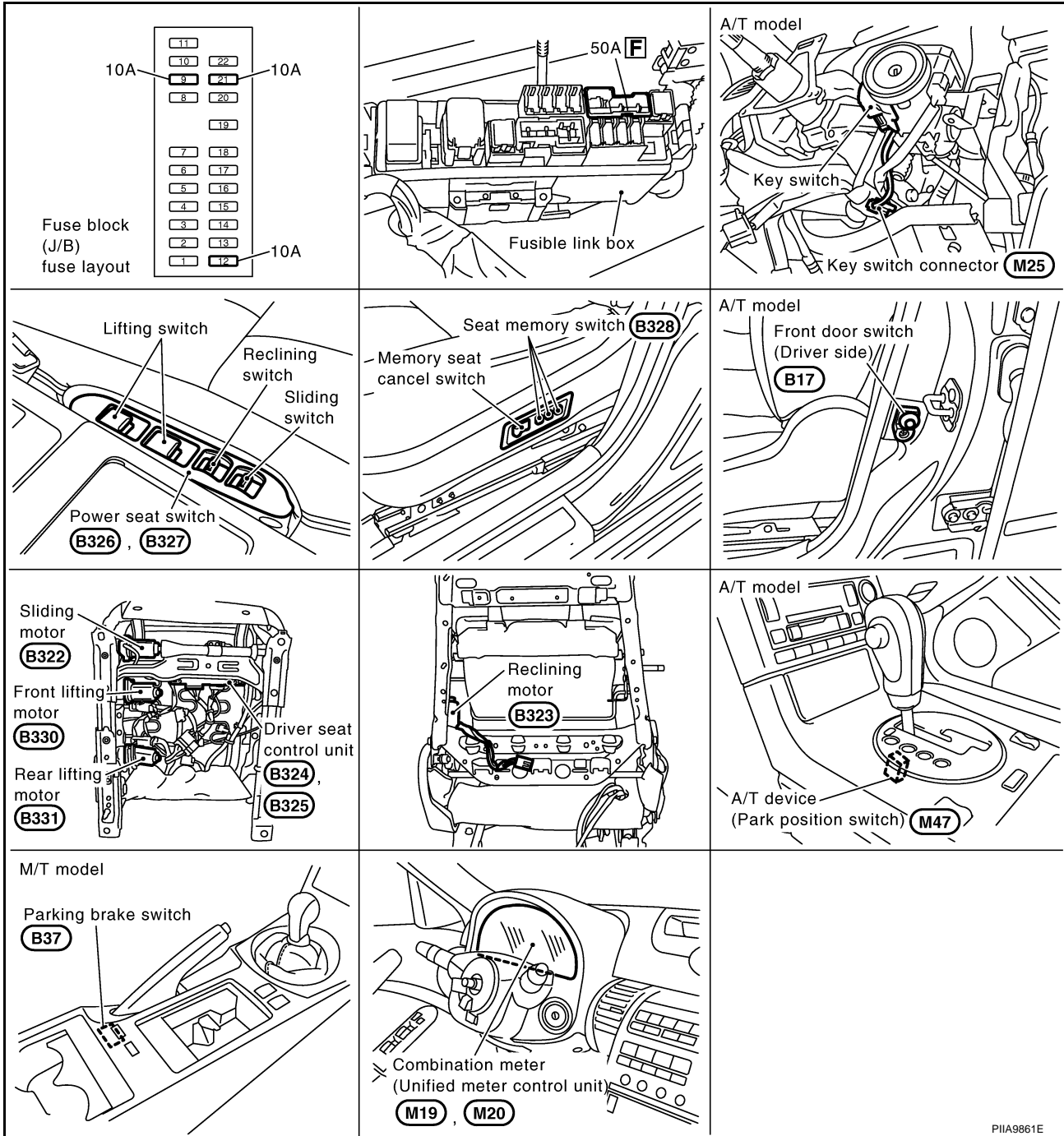

PIIA9861E

AUTOMATIC DRIVE POSITIONER

Schematic / For A/T Models

AIS00279

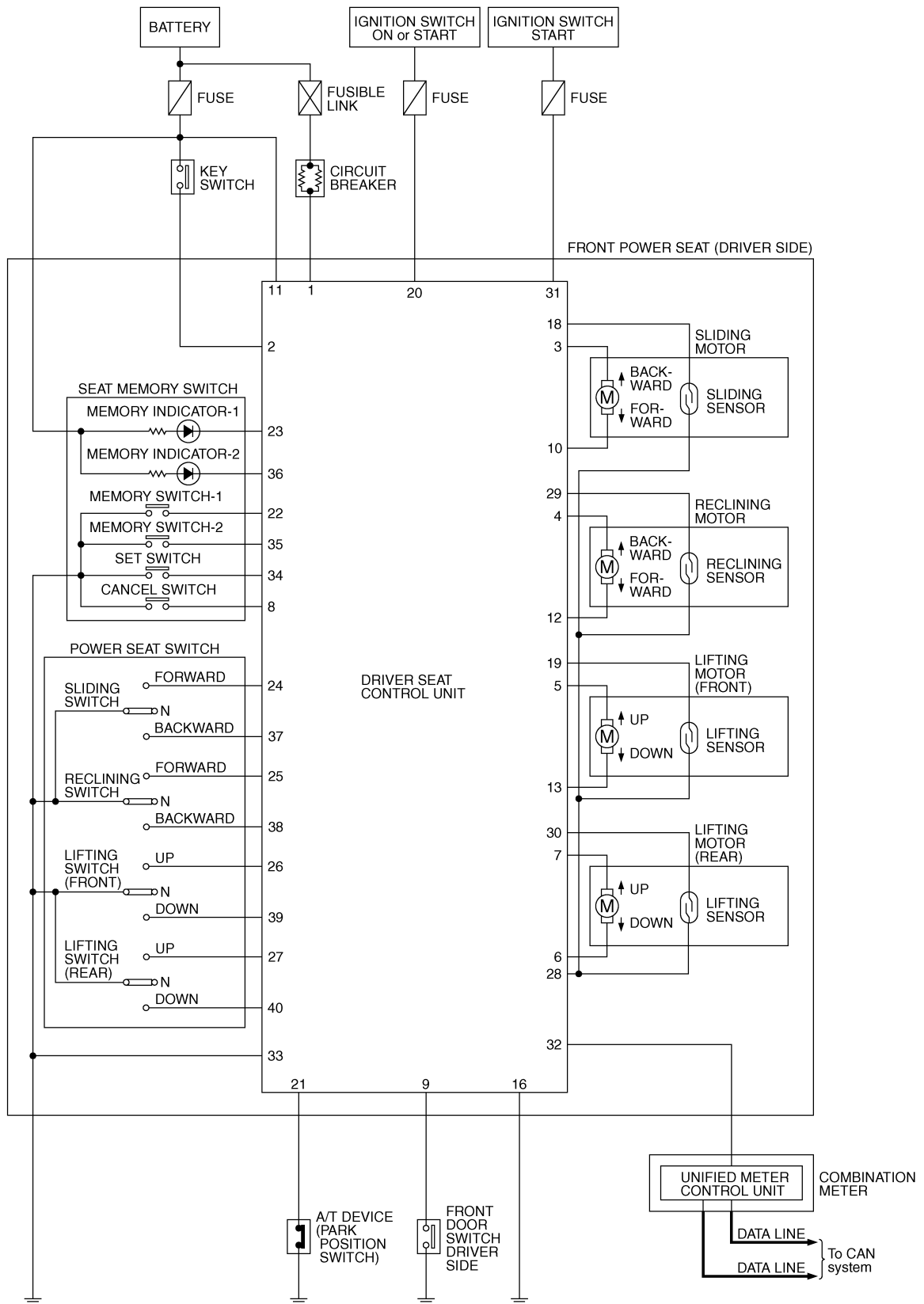

A
B
C
D
E
F
G
H
SE
J
K
L
M

AUTOMATIC DRIVE POSITIONER

Wiring Diagram-AUT/DP- / For A/T Models

AIS0027A

SE-AUT/DP-01

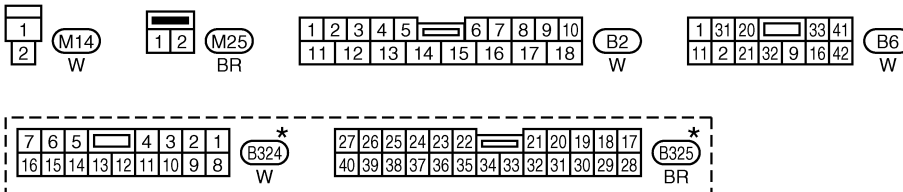
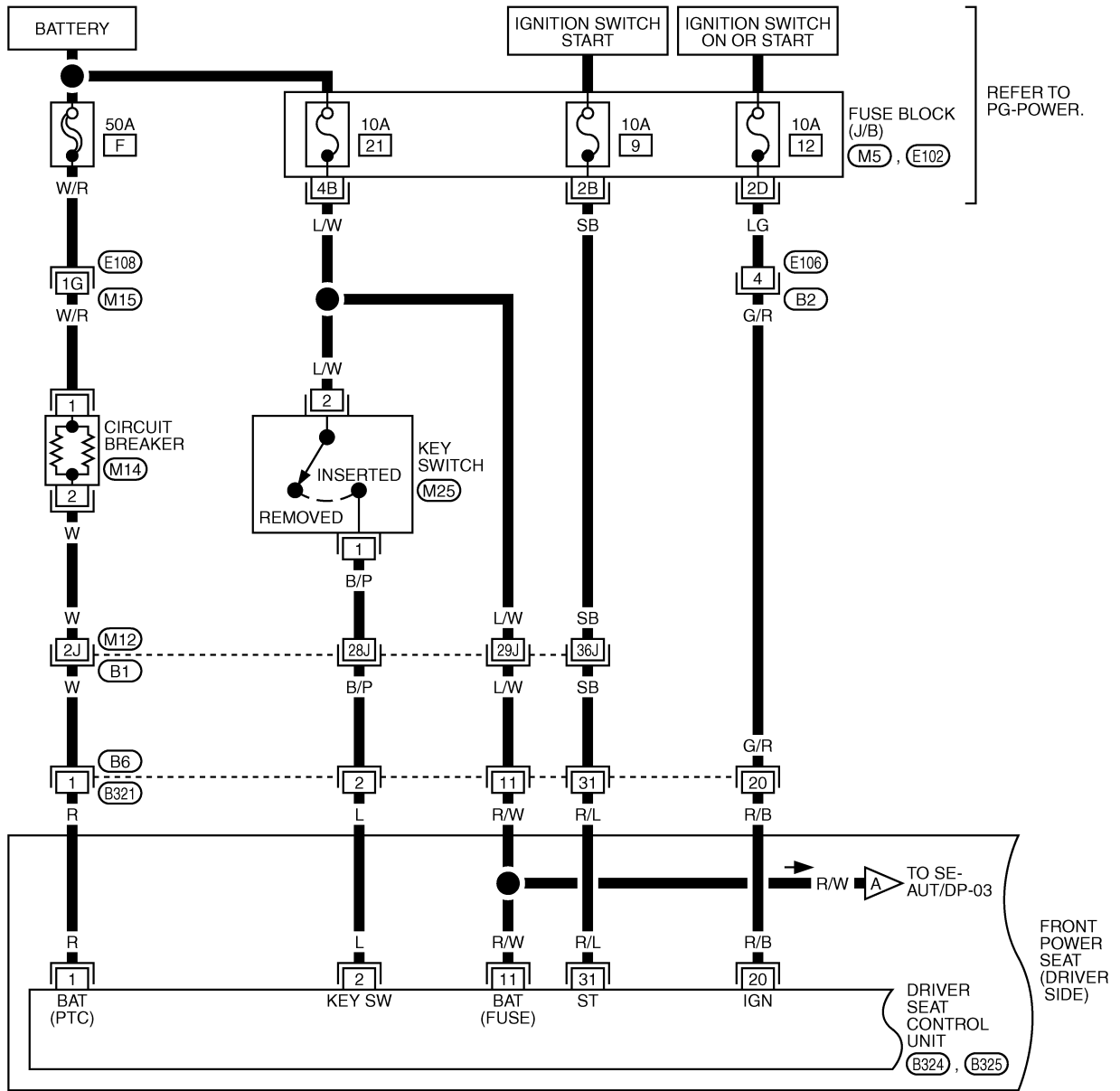

REFER TO THE FOLLOWING.
 (E108), (B1) -SUPER MULTIPLE JUNCTION (SMJ)
 (M5), (E102) -FUSE BLOCK-JUNCTION BOX (J/B)

*: THIS CONNECTOR IS NOT SHOWN IN "HARNESS LAYOUT", PG SECTION.

TIWT0654E

AUTOMATIC DRIVE POSITIONER

SE-AUT/DP-02

A
B
C
D
E
F
G
H
J
K
L
M

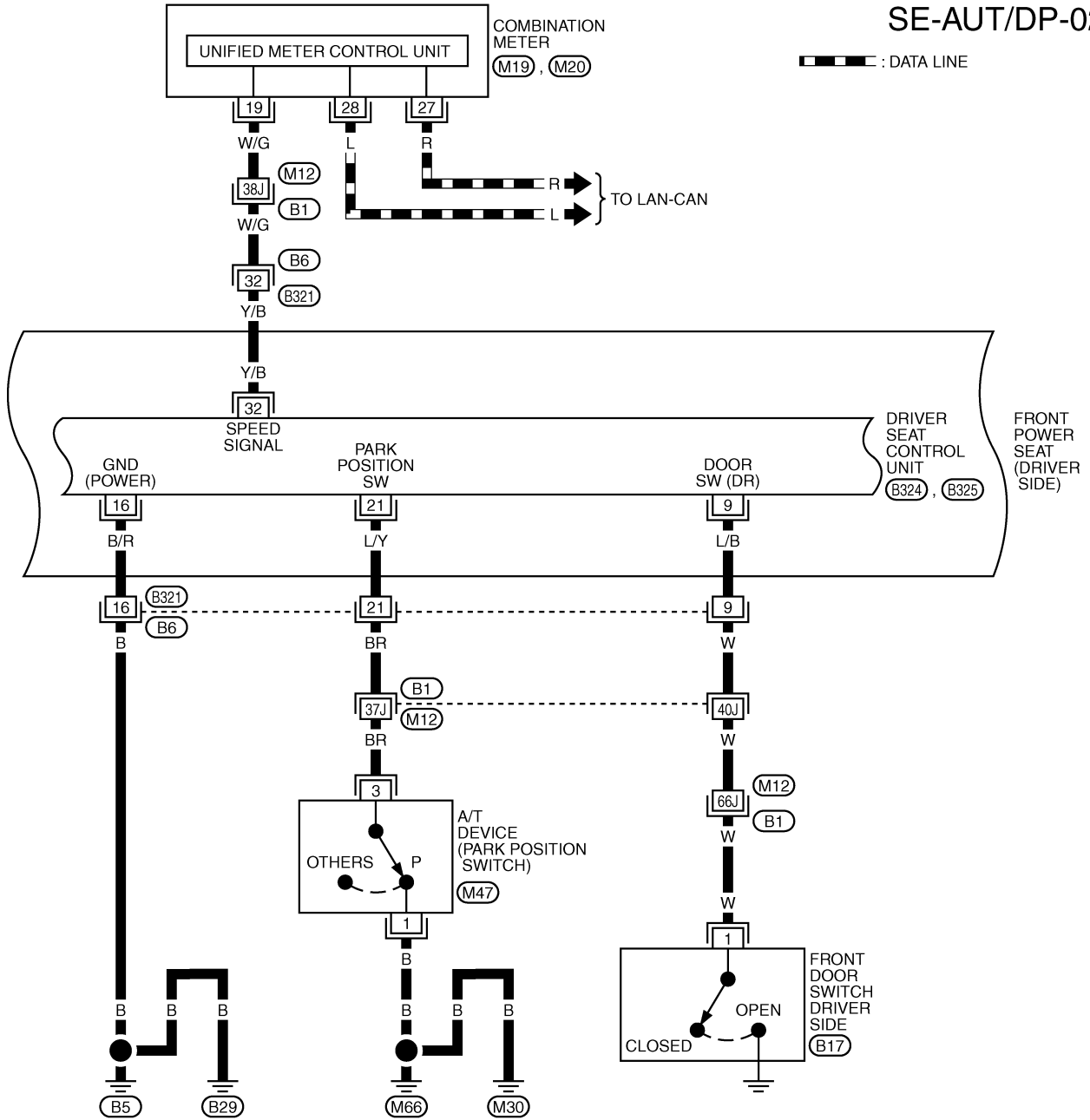

DATA LINE

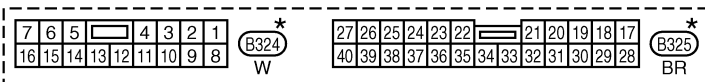
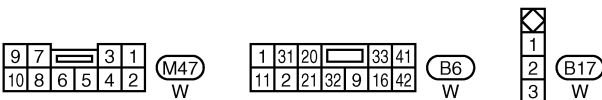
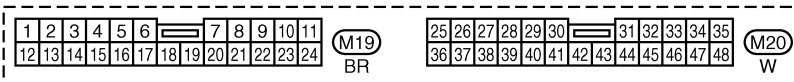

REFER TO THE FOLLOWING.
(B1) -SUPER MULTIPLE JUNCTION (SMJ)

*: THIS CONNECTOR IS NOT SHOWN IN "HARNESS LAYOUT", PG SECTION.

TIWT0655E

AUTOMATIC DRIVE POSITIONER

SE-AUT/DP-03

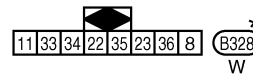
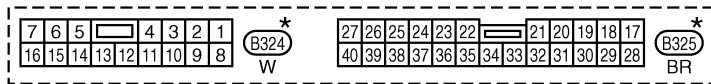
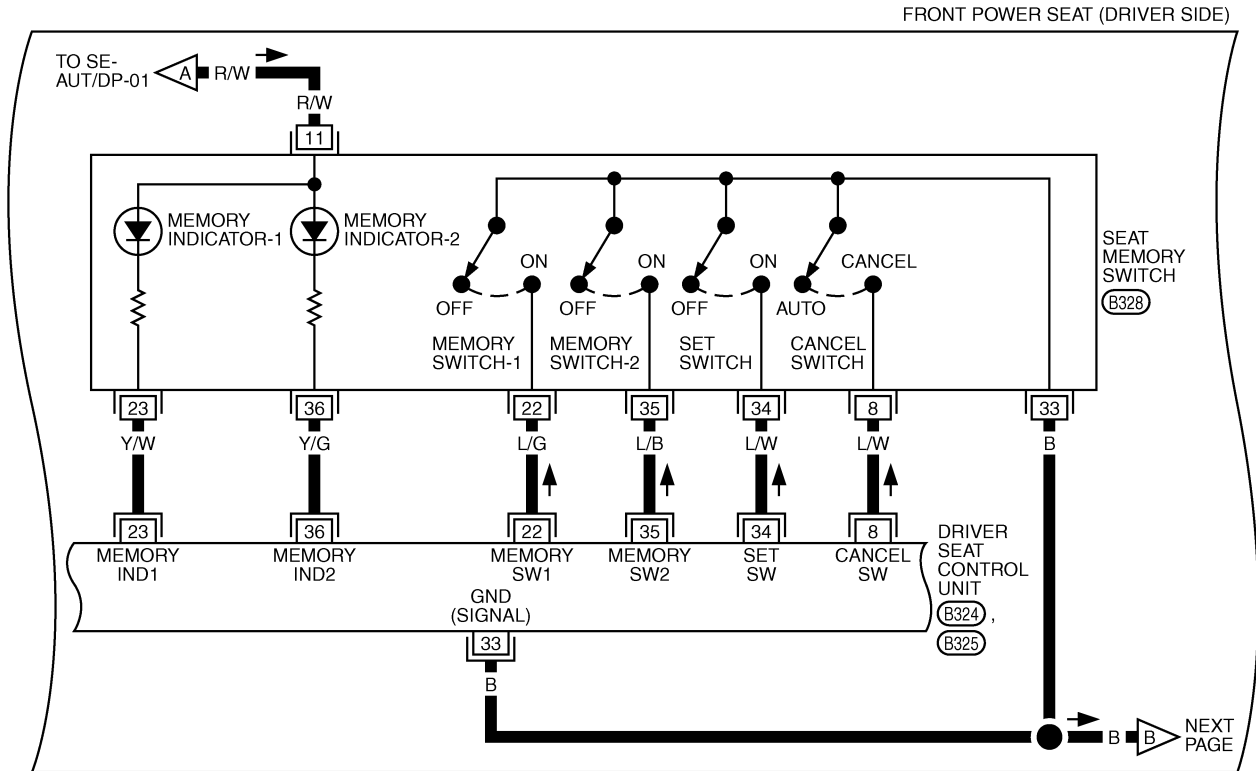

*: THIS CONNECTOR IS NOT SHOWN IN "HARNESS LAYOUT", PG SECTION.

TIWT0656E

AUTOMATIC DRIVE POSITIONER

SE-AUT/DP-04

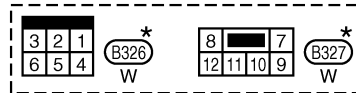
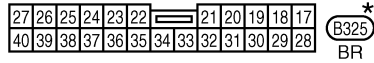
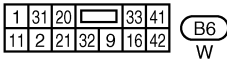
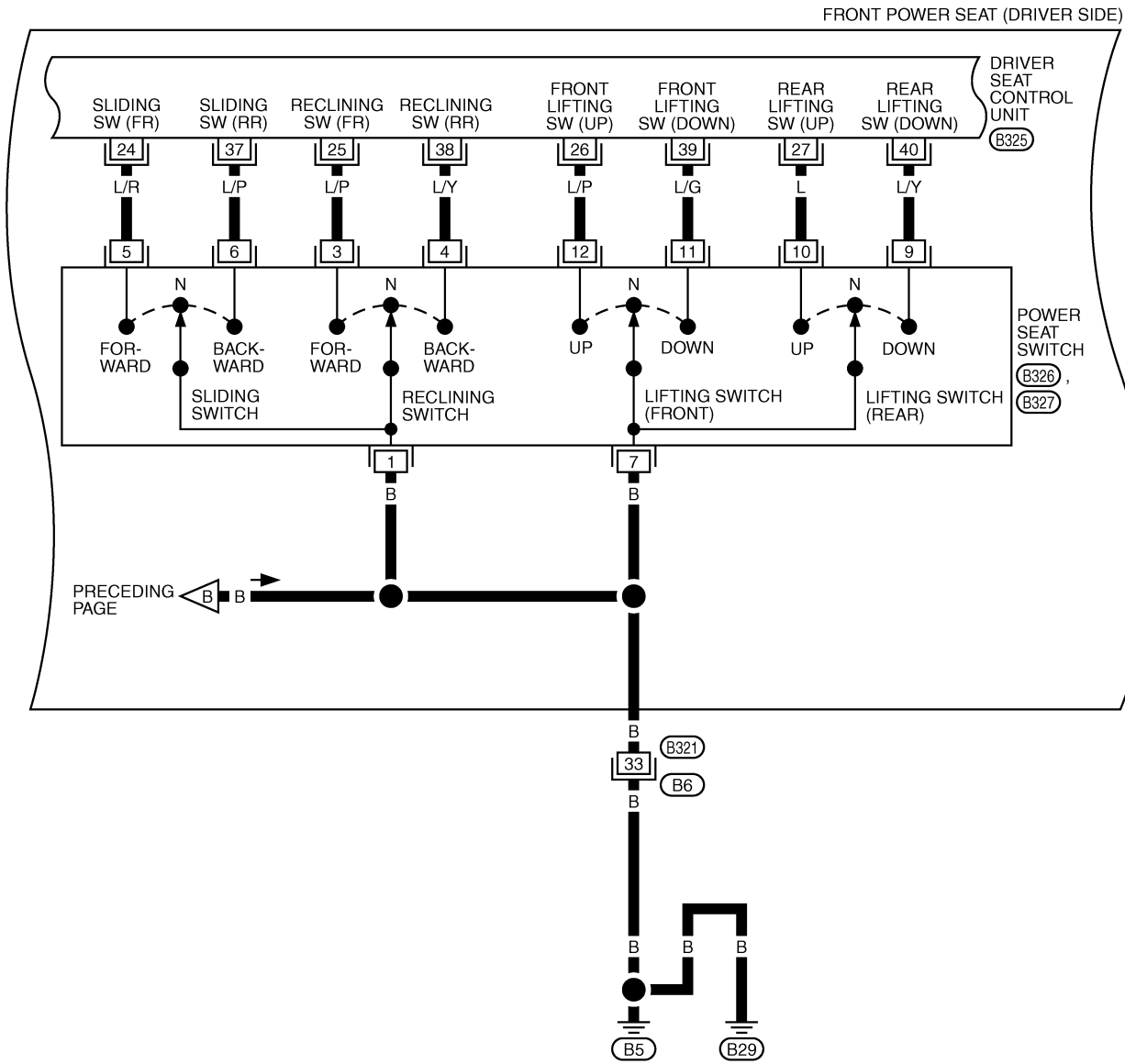

*: THIS CONNECTOR IS NOT SHOWN IN "HARNESS LAYOUT", PG SECTION.

TIWT0379E

AUTOMATIC DRIVE POSITIONER

SE-AUT/DP-05

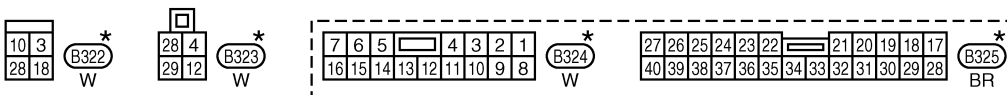
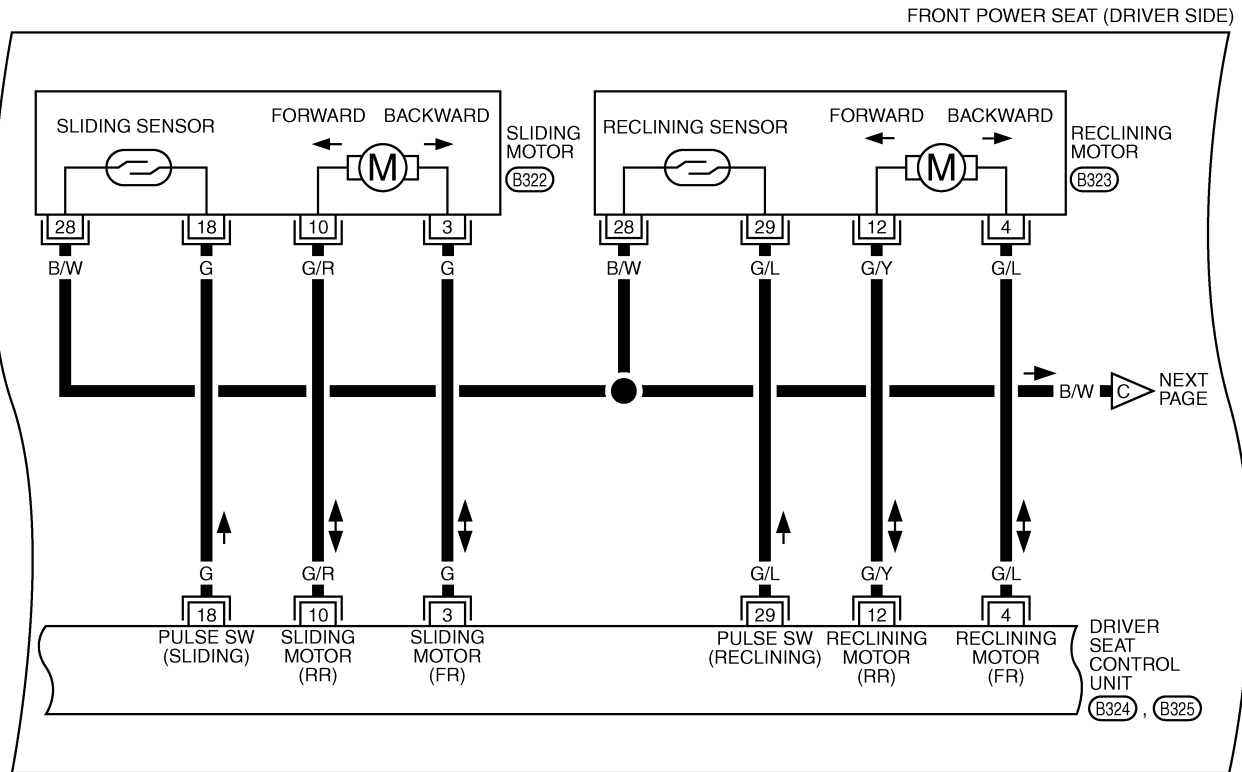

*: THIS CONNECTOR IS NOT SHOWN IN "HARNESS LAYOUT", PG SECTION.

TIWT0380E

AUTOMATIC DRIVE POSITIONER

SE-AUT/DP-06

A
B
C
D
E
F
G
H
SE
J
K
L
M

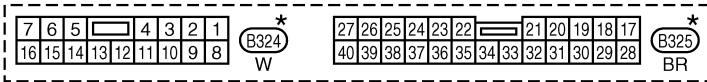
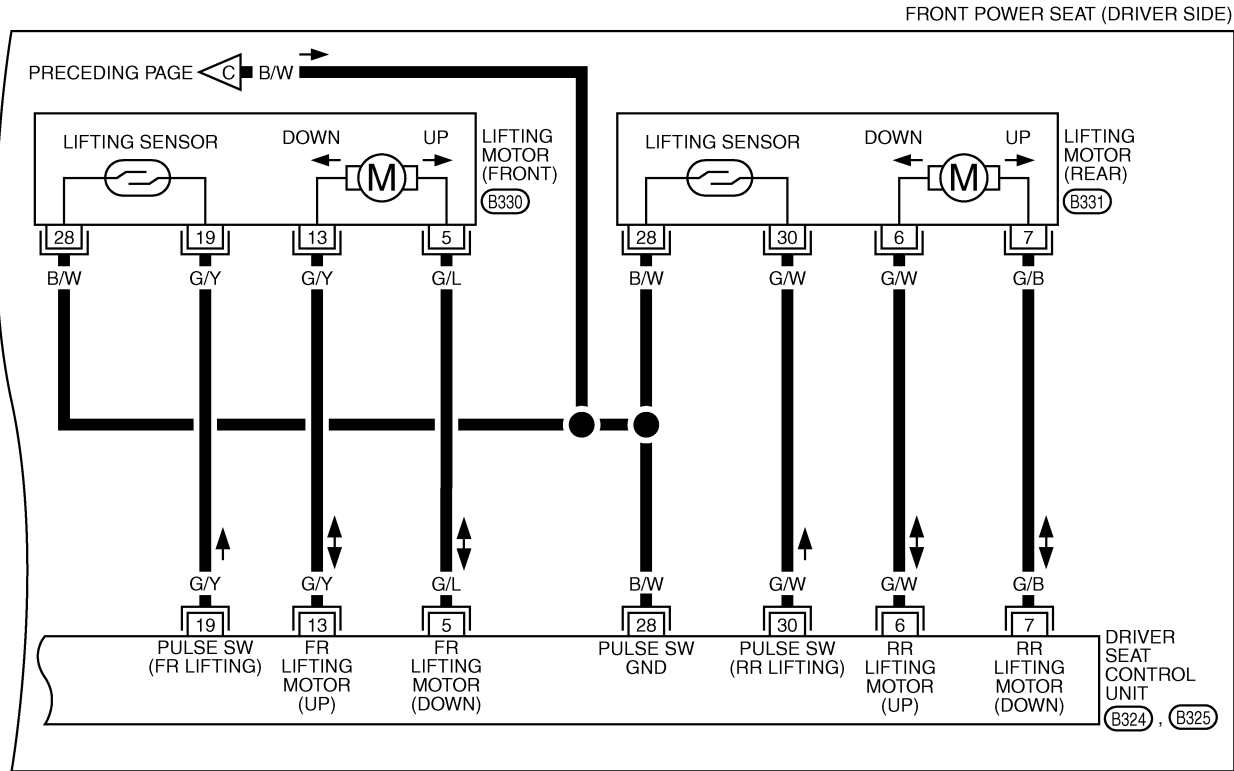

*: THIS CONNECTOR IS NOT SHOWN IN "HARNESS LAYOUT", PG SECTION.

TIWT0381E

AUTOMATIC DRIVE POSITIONER

Schematic / For M/T Models

AIS003KX

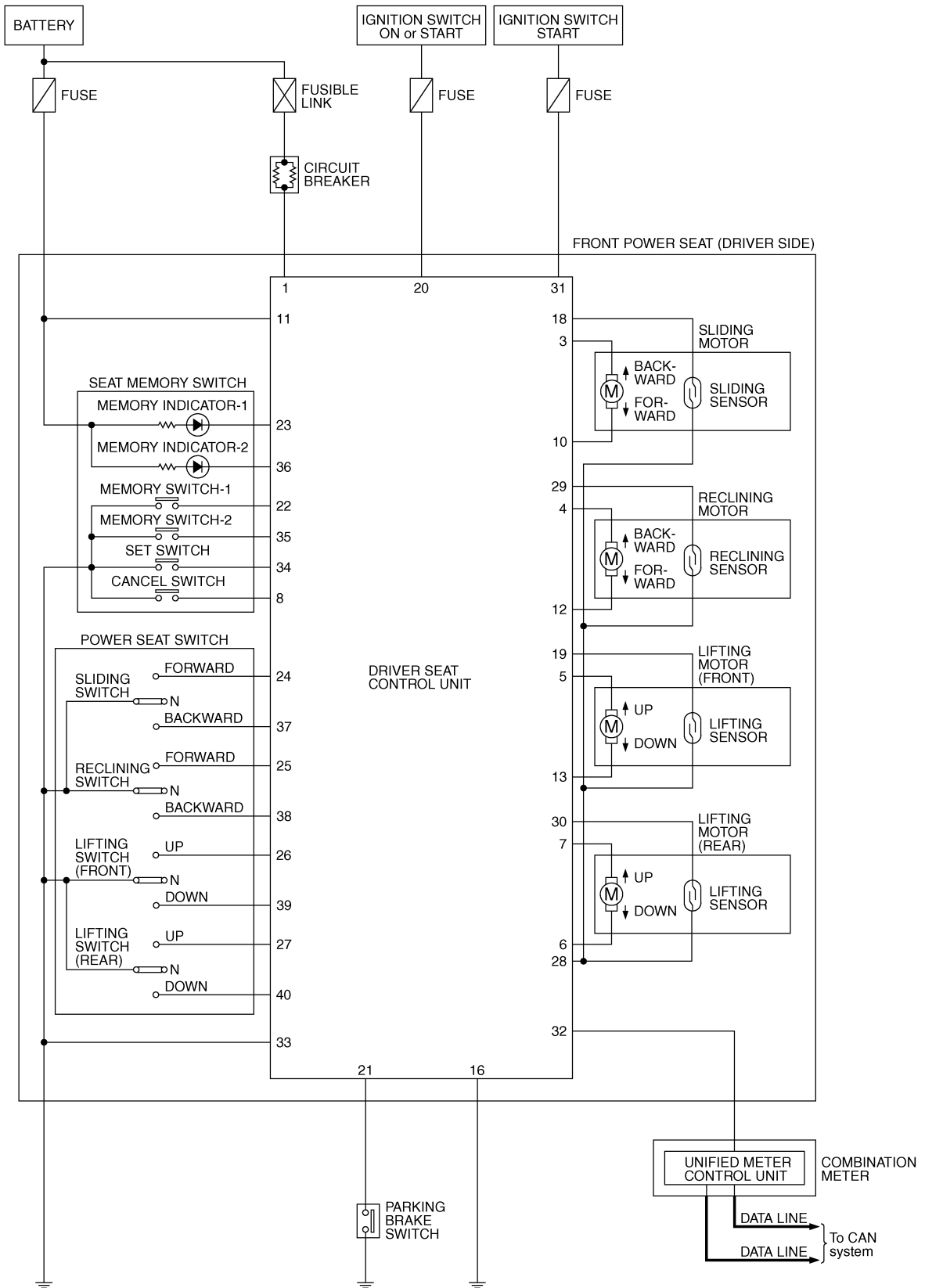

TIWT0465E

AUTOMATIC DRIVE POSITIONER

Wiring Diagram-SEAT- / For M/T Models

AIS003KY

SE-AUT/DP-07

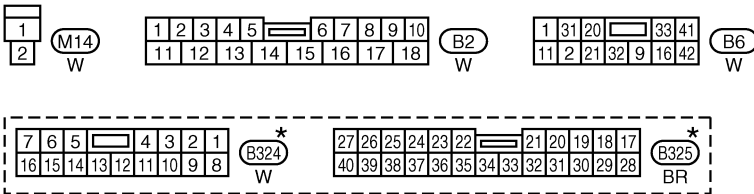
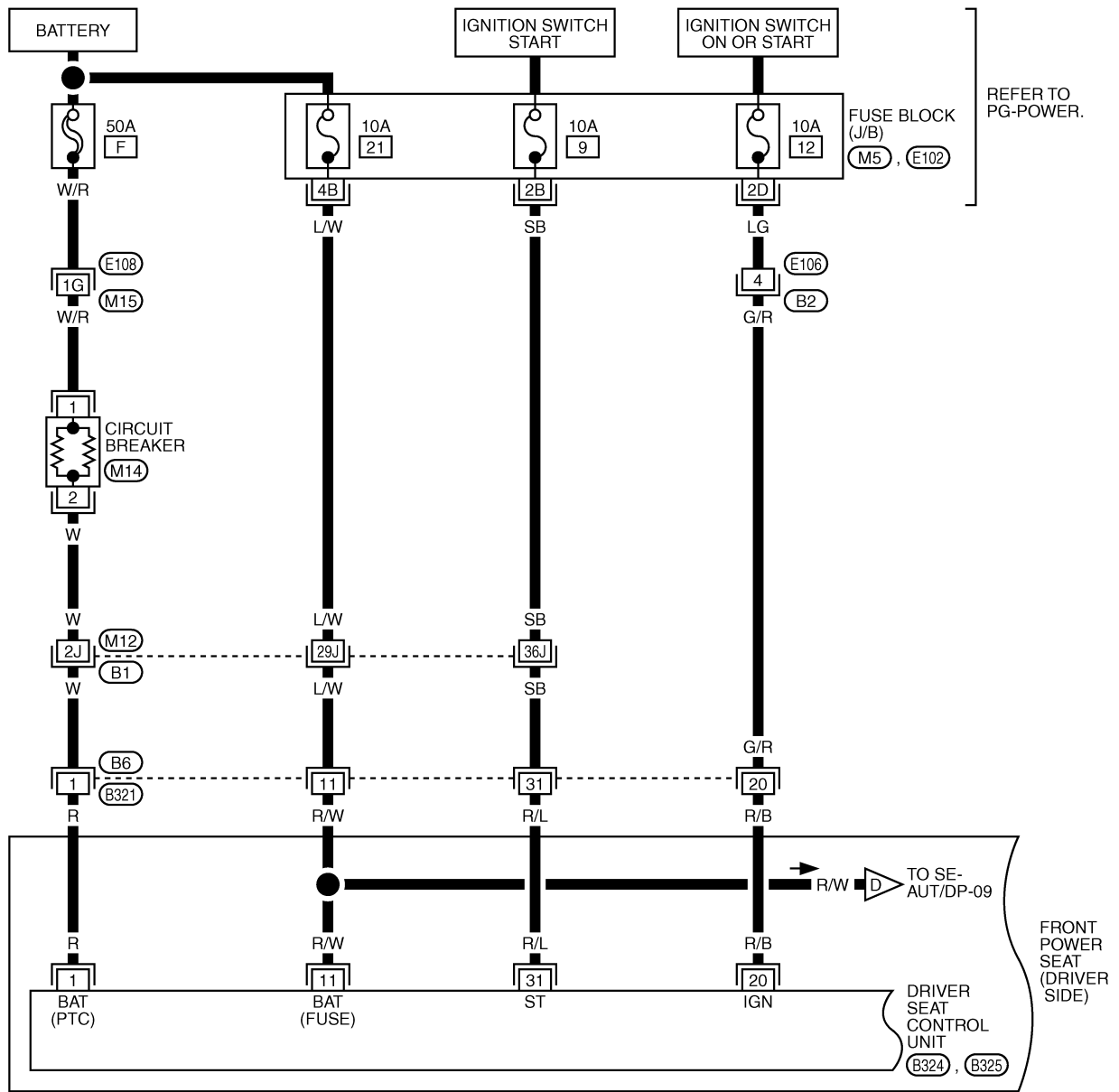

*: THIS CONNECTOR IS NOT SHOWN IN "HARNESS LAYOUT", PG SECTION.

REFER TO THE FOLLOWING.
 (E108), (B1) -SUPER MULTIPLE JUNCTION (SMJ)
 (M5), (E102) -FUSE BLOCK-JUNCTION BOX (J/B)

TIWT0657E

AUTOMATIC DRIVE POSITIONER

SE-AUT/DP-08

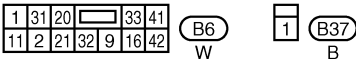
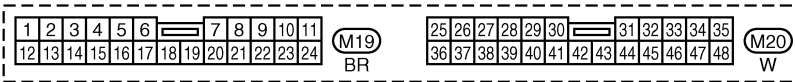
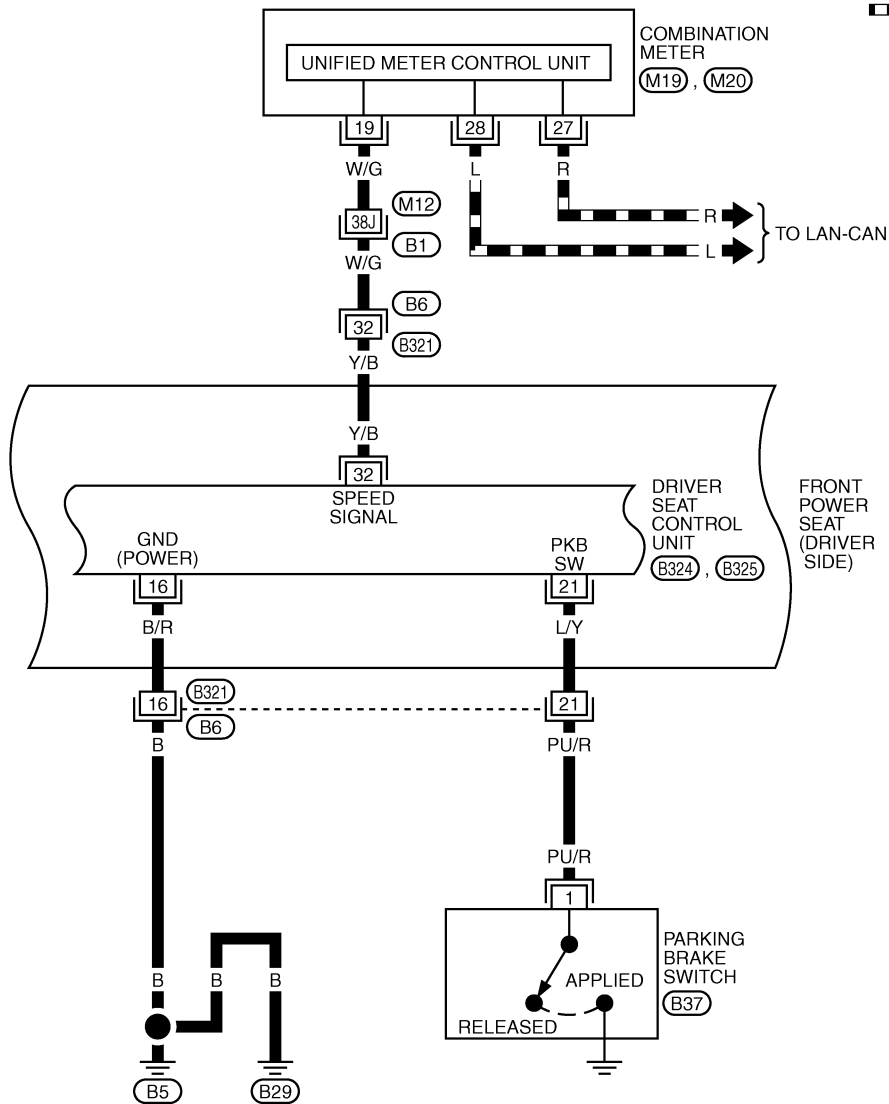

*: THIS CONNECTOR IS NOT SHOWN IN "HARNESS LAYOUT", PG SECTION.

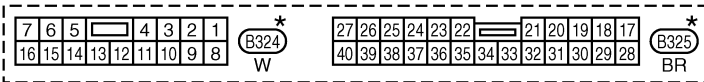

REFER TO THE FOLLOWING.

(B1) -SUPER MULTIPLE JUNCTION (SMJ)

TIWT0658E

AUTOMATIC DRIVE POSITIONER

SE-AUT/DP-09

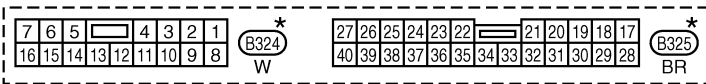
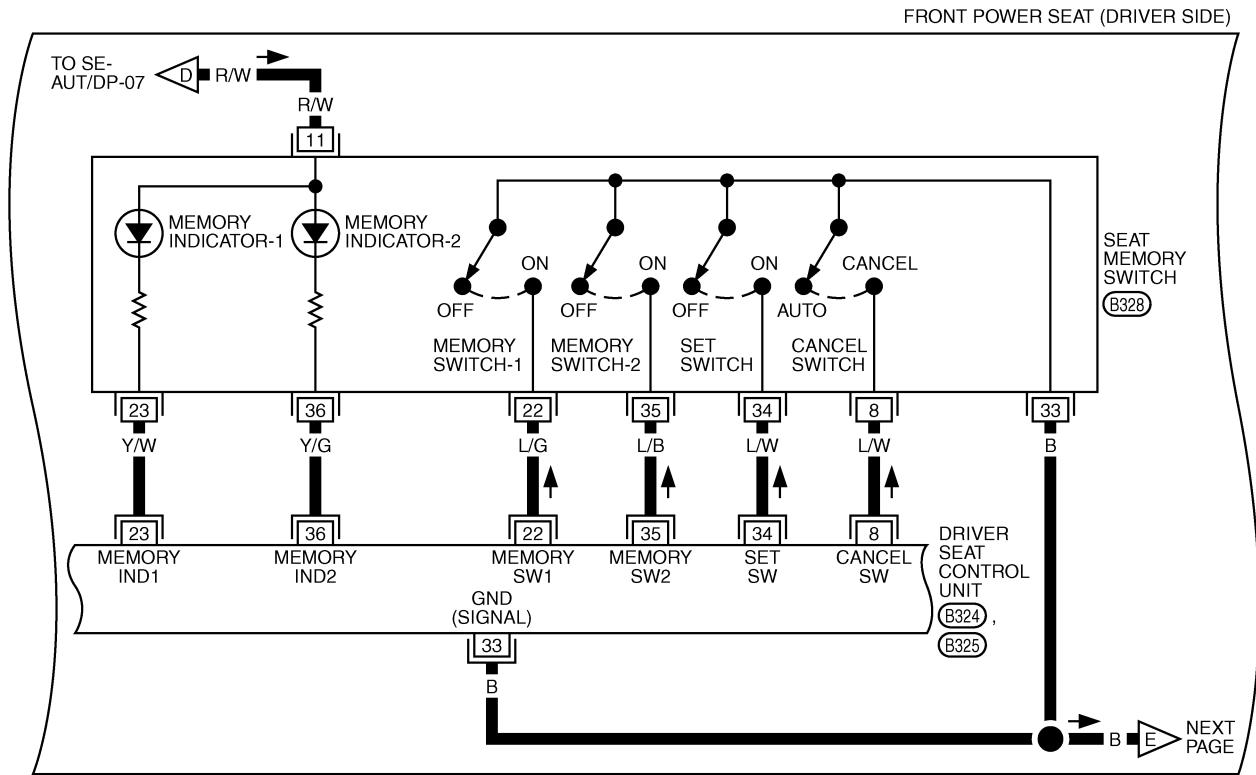

*: THIS CONNECTOR IS NOT SHOWN IN "HARNESS LAYOUT", PG SECTION.

TIWT0659E

AUTOMATIC DRIVE POSITIONER

SE-AUT/DP-10

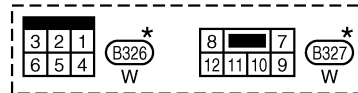
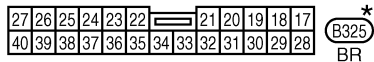
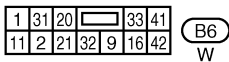
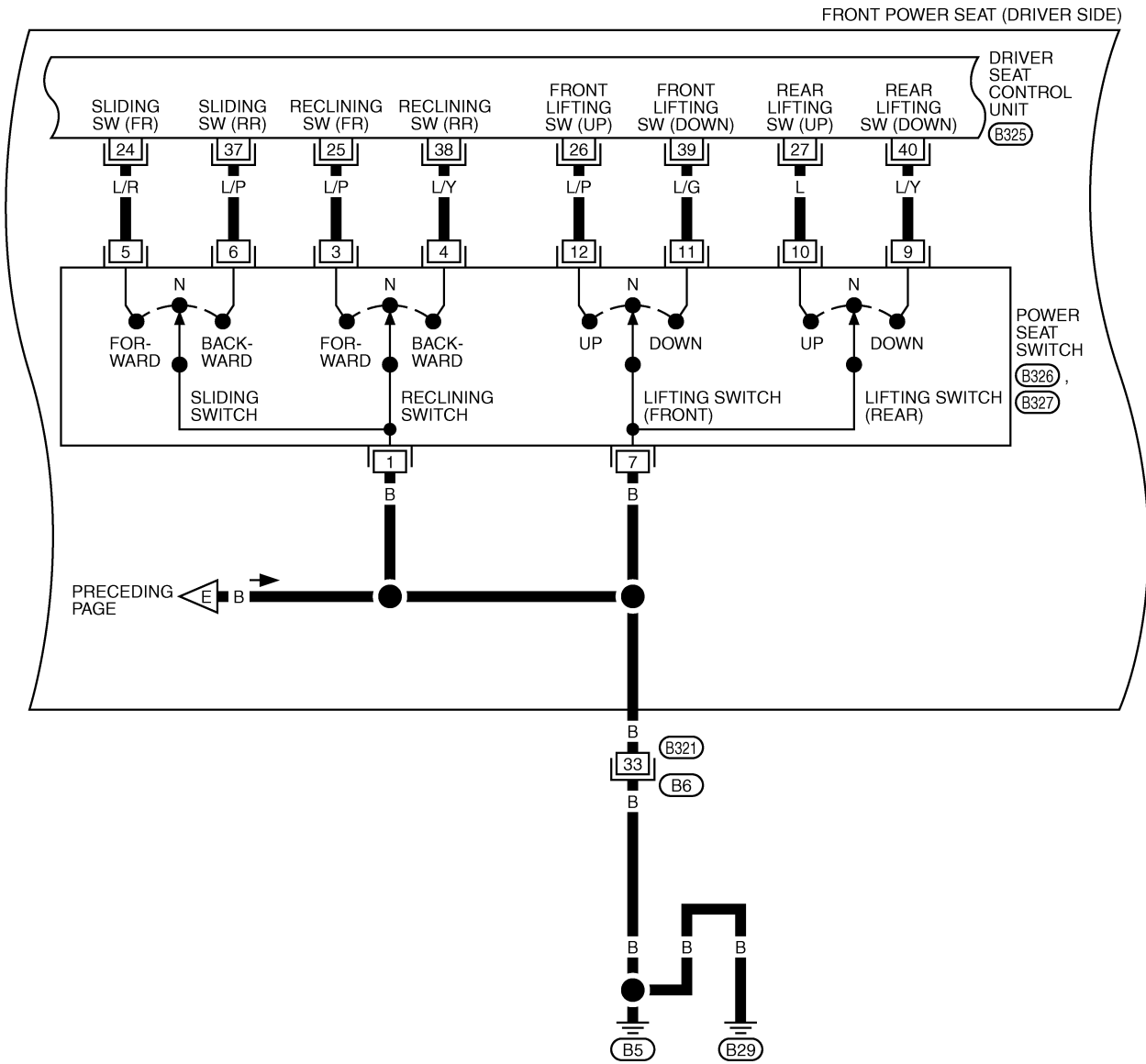

*: THIS CONNECTOR IS NOT SHOWN IN "HARNESS LAYOUT", PG SECTION.

TIWT0660E

AUTOMATIC DRIVE POSITIONER

SE-AUT/DP-11

A
B
C
D
E
F
G
H
J
K
L
M

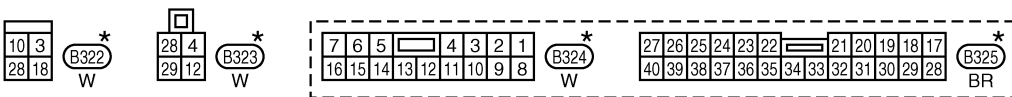
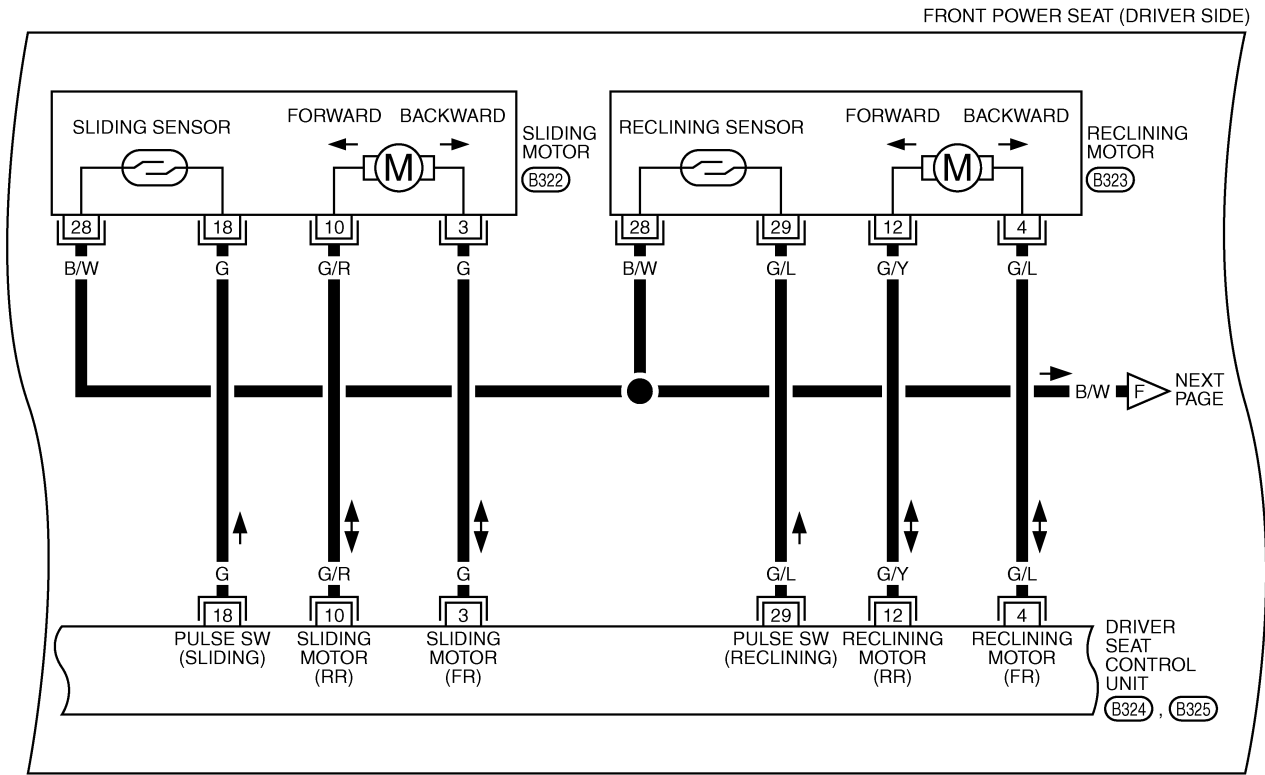

*: THIS CONNECTOR IS NOT SHOWN IN "HARNESS LAYOUT", PG SECTION.

TIWT0661E

AUTOMATIC DRIVE POSITIONER

SE-AUT/DP-12

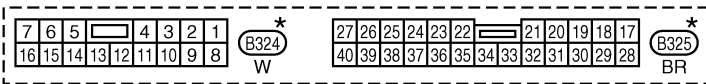
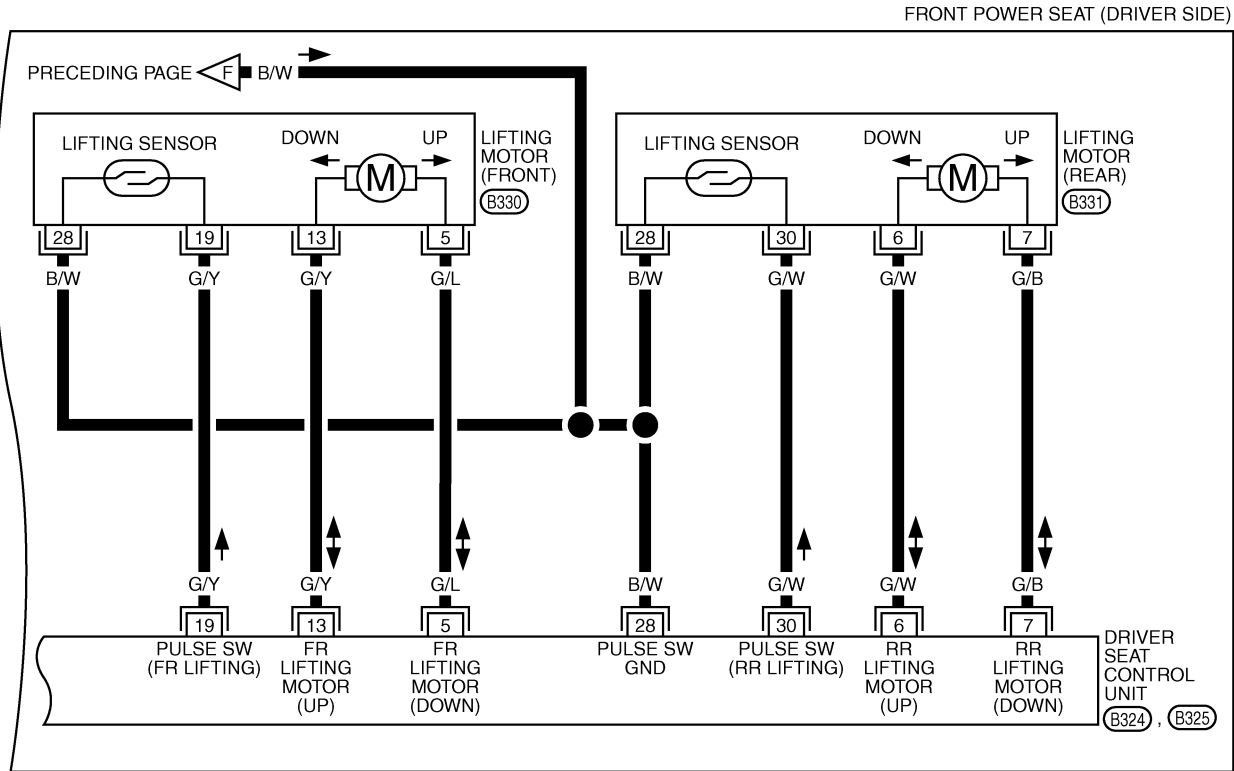

*: THIS CONNECTOR IS NOT SHOWN IN "HARNESS LAYOUT", PG SECTION.

TIWT0662E

AUTOMATIC DRIVE POSITIONER

Terminals and Reference Values for Driver Seat Control Unit

AIS002AL

TERMI- NAL	WIRE COLO R	ITEM	CONDITION		VOLTAGE (V) (Approx.)
1	R	Power source (Fusible link)	—		Battery voltage
2	L	Key switch signal* ¹	Key is inserted in ignition key cylinder.		Battery voltage
			Key is removed from ignition key cylinder.		0
3	G	Sliding motor FORWARD signal	Sliding switch	FORWARD operation (Motor operated)	Battery voltage
				OFF	0
4	G/L	Reclining motor FORWARD signal	Reclining switch	FORWARD operation (Motor operated)	Battery voltage
				OFF	0
5	G/L	Front lifting motor DOWN signal	Lifting switch (Front)	DOWN operation (Motor operated)	Battery voltage
				OFF	0
6	G/W	Rear lifting motor UP signal	Lifting switch (Rear)	UP operation (Motor operated)	Battery voltage
				OFF	0
7	G/B	Rear lifting motor DOWN signal	Lifting switch (Rear)	DOWN operation (Motor operated)	Battery voltage
				OFF	0
8	L/W	Cancel switch signal	Cancel switch	: ON	0
				: OFF	5
9	L/B	Front door switch* ¹ (driver side) signal	Driver door open (ON)		0
			Driver door closed (OFF)		Battery voltage
10	G/R	Sliding motor BACKWARD signal	Sliding switch	BACKWARD operation (Motor operated)	Battery voltage
				OFF	0
11	R/W	Power source (Fuse)	Ignition switch OFF		Battery voltage
12	G/Y	Reclining motor BACKWARD signal	Reclining switch	BACKWARD operation (Motor operated)	Battery voltage
				OFF	0
13	G/Y	Front lifting motor UP signal	Lifting switch (Front)	UP operation (Motor operated)	Battery voltage
				OFF	0
16	B/R	Ground (Power)	—		0
18	G	Sliding sensor signal	Sliding motor operation		<p style="text-align: right; font-size: small;">S11A0690J</p>
			Other than above.		

A
B
C
D
E
F
G
H
SE
J
K
L
M

AUTOMATIC DRIVE POSITIONER

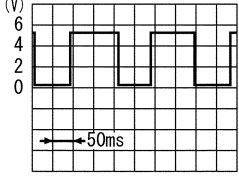
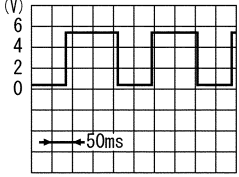
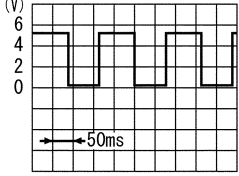
TERMI- NAL	WIRE COLO R	ITEM	CONDITION	VOLTAGE (V) (Approx.)
19	G/Y	Lifting sensor front signal	Lifting motor (front) operation	 SIIA0691J
			Other than above.	0 or 5
20	R/B	Ignition switch (ON)	Ignition switch (ON or START position)	Battery voltage
21	L/Y	A/T device* ¹	Selector lever in P-position.	0
			Selector lever in other than P-position.	5
		Parking brake switch input signal* ²	Parking brake switch applied (ON)	0
			Parking brake switch released	5
22	L/G	Memory switch 1 signal	Memory switch 1 : ON	0
			Memory switch 1 : OFF	5
23	Y/W	Power seat memory indicator 1 signal.	Memory indicator 1 : ON	0
			Memory indicator 1 : OFF	Battery voltage
24	L/R	Sliding switch FORWARD signal	Sliding switch FORWARD operation	0
			Sliding switch OFF	Battery voltage
25	L/P	Reclining switch FORWARD signal	Reclining switch FORWARD operation	0
			Reclining switch OFF	Battery voltage
26	L/P	Front lifting switch UP signal	Lifting switch (front) UP operation	0
			Lifting switch (front) OFF	Battery voltage
27	L	Rear lifting switch UP signal	Lifting switch (rear) UP operation	0
			Lifting switch (rear) OFF	Battery voltage
28	B/W	Lifting sensor ground	—	0
29	G/L	Reclining sensor signal	Reclining motor operation	 SIIA0692J
			Other than above.	0 or 5
30	G/W	Lifting sensor rear signal	Lifting motor (rear) operation	 SIIA0693J
			Other than above.	0 or 5
31	R/L	Ignition switch (START)	Ignition switch (START position)	Battery voltage

AUTOMATIC DRIVE POSITIONER

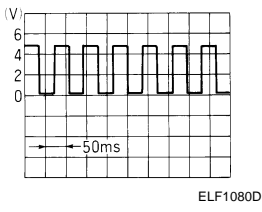
TERMI- NAL	WIRE COLO R	ITEM	CONDITION	VOLTAGE (V) (Approx.)	
32	Y/B	Vehicle speed signal	When vehicle speed is approx. 40 km/h (25MPH).		
			Ignition switch ON	5	
33	B	Ground (signal)	Ignition switch ON	0	
34	L/W	Seat memory setting switch signal	Setting switch	: ON	0
				: OFF	5
35	L/B	Memory switch 2 signal	Memory switch 2	: ON	0
				: OFF	5
36	Y/G	Power seat memory indicator 2 signal.	Memory indicator 2	: ON	0
				: OFF	Battery voltage
37	L/P	Sliding switch BACKWARD signal	Sliding switch	BACKWARD operation	0
				OFF	Battery voltage
38	L/Y	Reclining switch BACKWARD signal	Reclining switch	BACKWARD operation	0
				OFF	Battery voltage
39	L/G	Lifting switch DOWN signal	Lifting switch (front)	DOWN operation	0
				OFF	Battery voltage
40	L/Y	Lifting switch DOWN signal	Lifting switch (rear)	DOWN operation	0
				OFF	Battery voltage

- *1: A/T models only
- *2: M/T models only

On Board Diagnosis

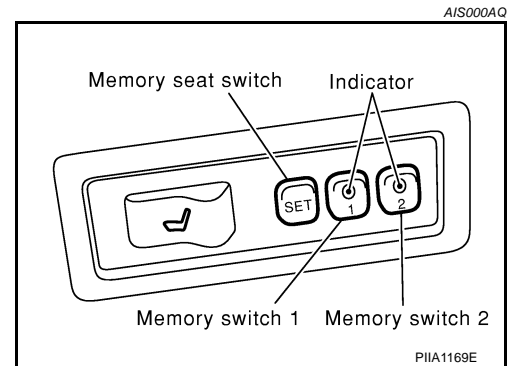

AUTOMATIC DRIVE POSITIONER

HOW TO PERFORM SELF-DIAGNOSIS

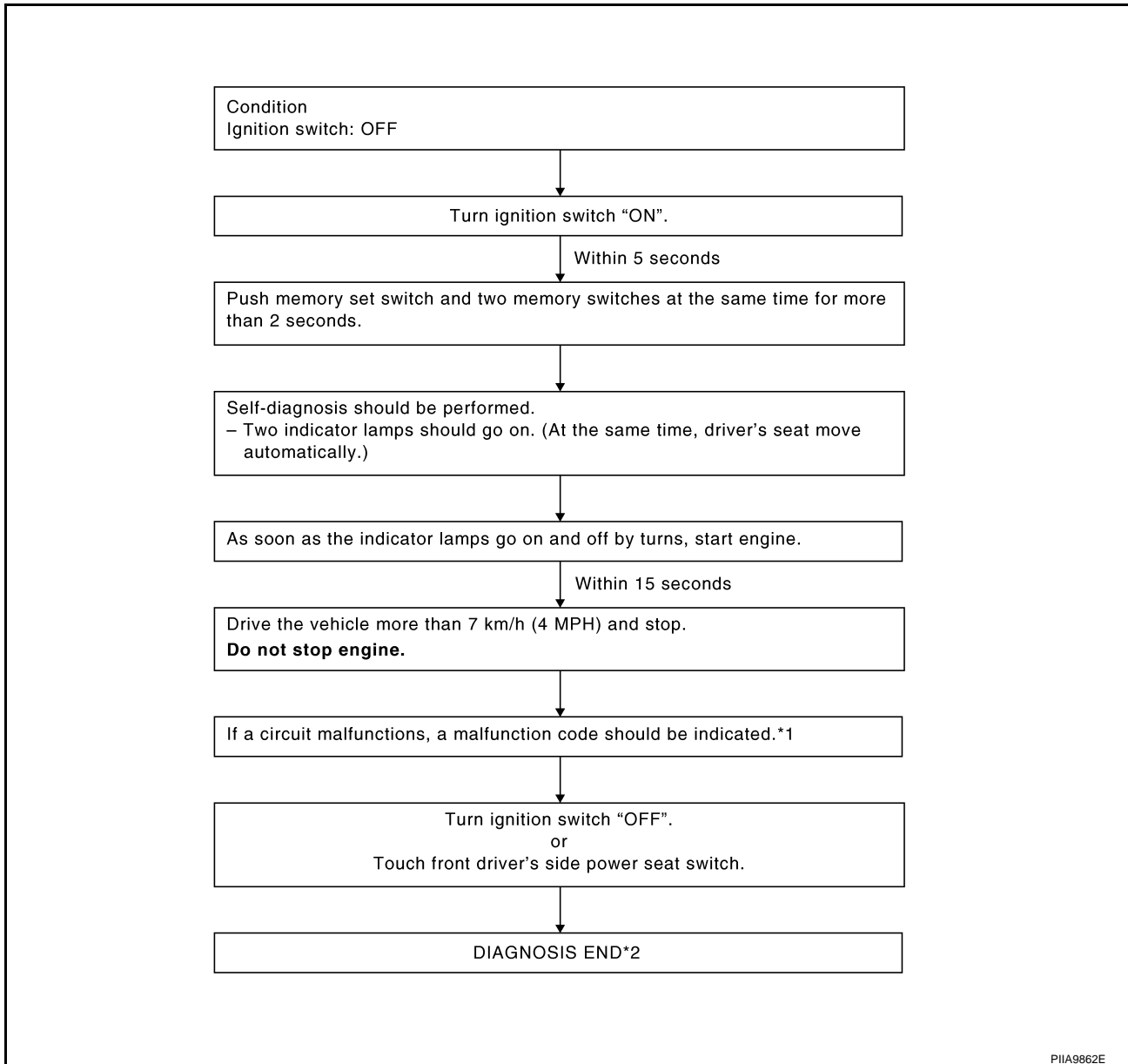



*1: If no malfunction is indicated, self-diagnosis will end after the vehicle speed sensor diagnosis is performed.

*2: Diagnosis ends after self-diagnostic results have been indicated for 10 minutes if left unattended.

AUTOMATIC DRIVE POSITIONER

MALFUNCTION CODE TABLE

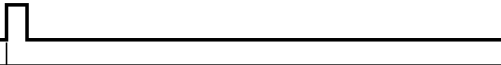
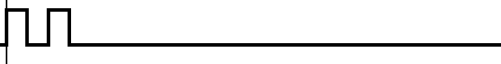
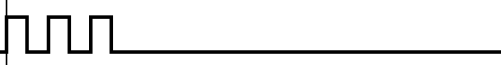
In this mode, a malfunction code is indicated by the number of flashes from the automatic drive positioner indicator lamps (indicator lamp 1, indicator lamp 2) as shown below.

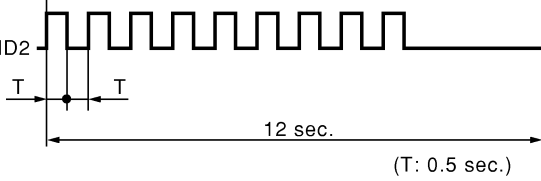
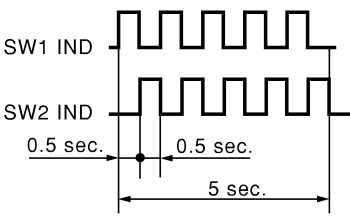
Code No.	Detected items	Indication of seat memory switches 1 and 2	Explanation
1	Seat sliding	IND1, IND2 	While the seat motors are moving for 2.5 seconds, if the number of seat sliding/reclining/lifting encoder pulses changes 2 times or less, the seat device is determined to be malfunctioning.
2	Seat reclining	IND1, IND2 	
3	Seat lifting front	IND1, IND2 	
4	Seat lifting rear	IND1, IND2 	
9	Vehicle speed sensor circuit	IND1, IND2 	If the vehicle speed sensor output of less than 7 km/h (4 MPH) is detected, the vehicle speed sensor is determined to be malfunctioning.
-	No malfunction in the above items	SW1 IND 	—

SEL597W

Code No.	Detected items	Diagnostic procedure	Reference page	Code No.	Detected items	Diagnostic procedure	Reference page
1	Seat sliding	PROCEDURE 2 (Sliding sensor check)	SE-39	4	Seat lifting rear	PROCEDURE 5 [Lifting sensor (rear) check]	SE-42
		PROCEDURE 6 (Sliding motor check)	SE-43			PROCEDURE 9 [Lifting motor (rear) check]	SE-46
2	Seat reclining	PROCEDURE 3 (Reclining sensor check)	SE-40	9	Vehicle speed sensor	PROCEDURE 12 (Vehicle speed sensor check)	SE-48
		PROCEDURE 7 (Reclining motor check)	SE-44				
3	Seat lifting front	PROCEDURE 4 [Lifting sensor (front) check]	SE-41				
		PROCEDURE 8 [Lifting motor (front) check]	SE-45				

AUTOMATIC DRIVE POSITIONER

Trouble Diagnosis WORK FLOW

AIS000AR

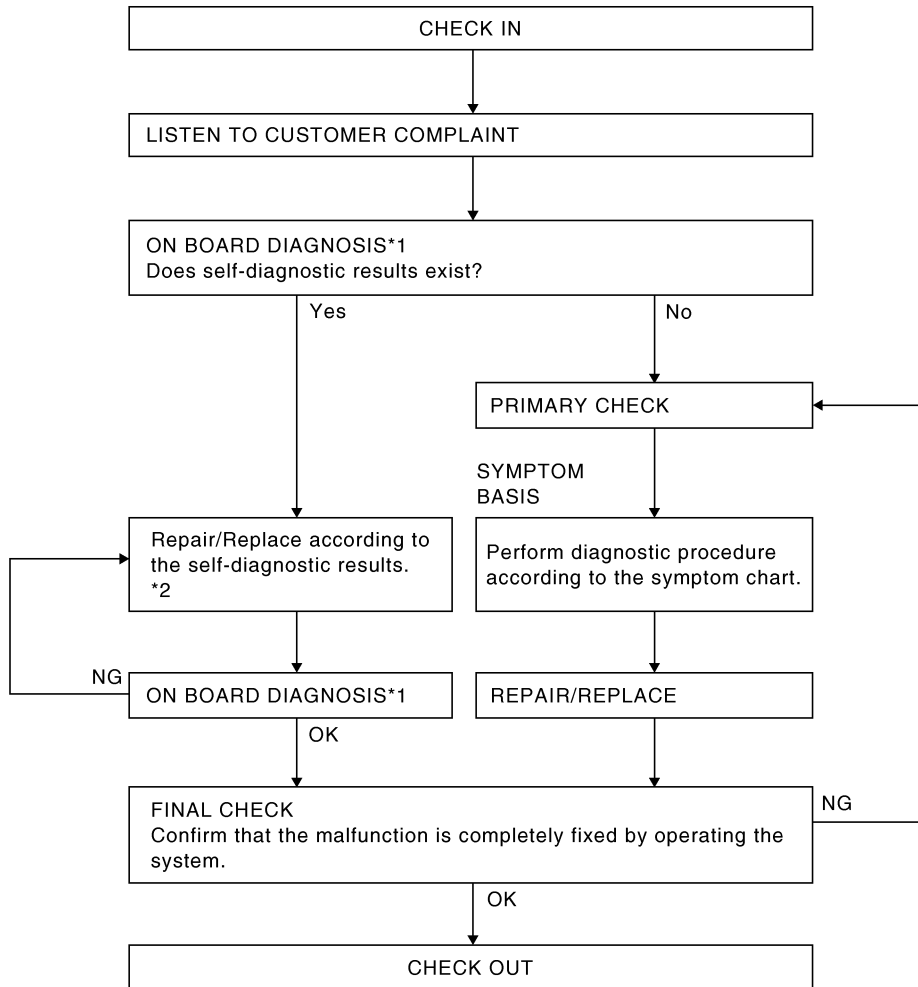

PIIA9863E

*1: Refer to [SE-32, "HOW TO PERFORM SELF-DIAGNOSIS"](#) .

*2: Refer to [SE-33, "MALFUNCTION CODE TABLE"](#) .

AUTOMATIC DRIVE POSITIONER

PRELIMINARY CHECK

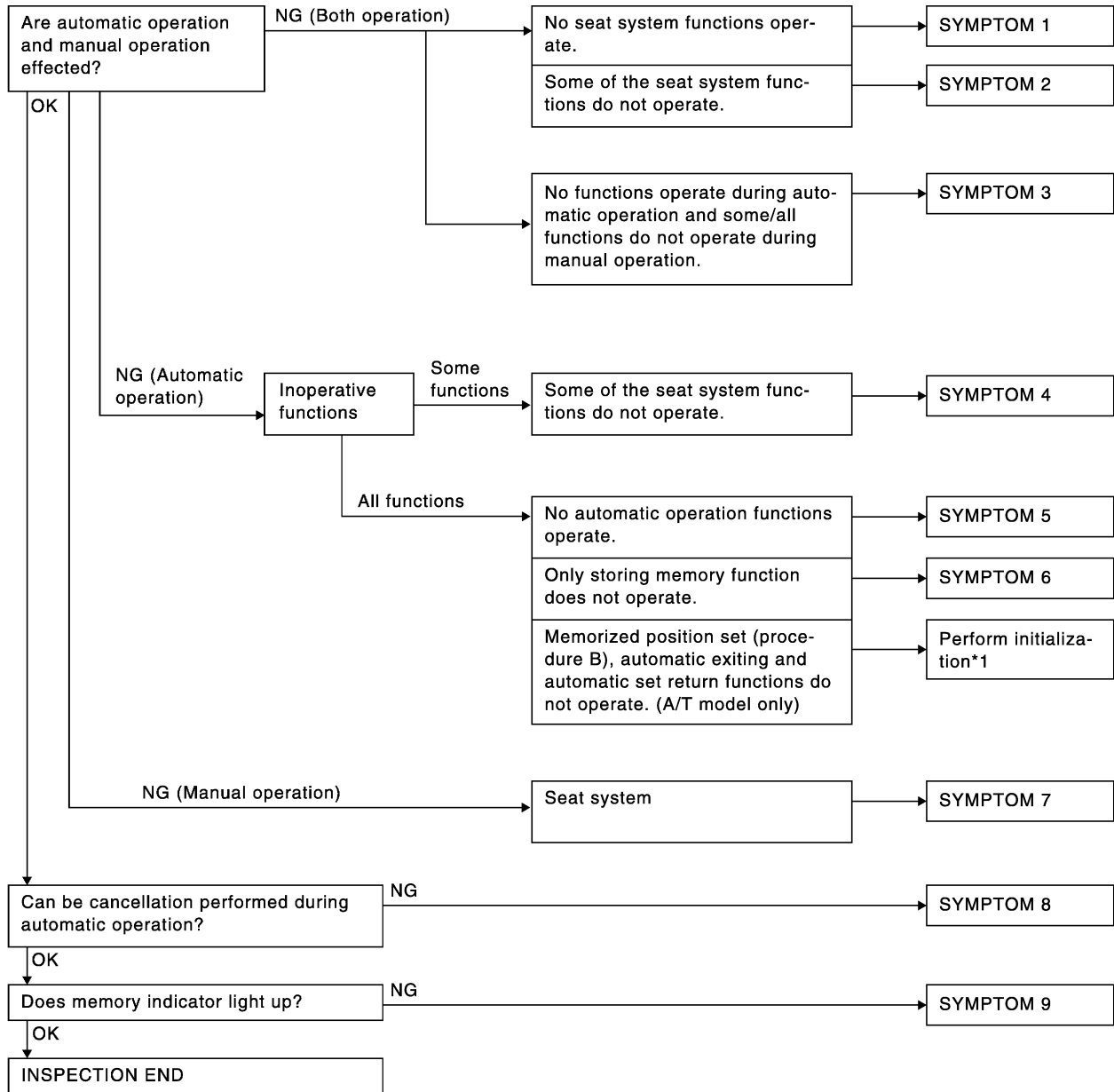

SEL600WA

*1: After reconnecting battery cable, perform initialization procedure A or B.
If initialization has not been performed, automatic drive positioner will not operate.

PROCEDURE A

1. Insert key in the ignition key cylinder. (Ignition switch is in "OFF" position.)
2. Open → close → open driver side door. (Do not perform with the door switch operation.)
3. End

PROCEDURE B

1. Drive the vehicle at more than 25 km/h (16 MPH).
2. End

After performing preliminary check, go to symptom chart below.

Before starting trouble diagnoses below, perform preliminary check, [SE-34. "WORK FLOW"](#) . Symptom numbers in the symptom chart correspond with those of preliminary check.

AUTOMATIC DRIVE POSITIONER

SYMPTOM CHART

- When starting each diagnostic procedure, first check corresponding harness connection.
- Replace driver seat control unit when automatic drive positioner system does not operate properly even if corresponding diagnostic procedure (except the procedure 6, 7, 8 and 9) is done.

PROCEDURE		Diagnostic procedure						
REFERENCE PAGE		SE-38	SE-39	SE-40	SE-41	SE-42	SE-43	SE-44
SYMPTOM		DIAGNOSTIC PROCEDURE 1 (Power supply and ground circuit for Driver's seat control unit)	DIAGNOSTIC PROCEDURE 2 (Sliding sensor check)	DIAGNOSTIC PROCEDURE 3 (Reclining sensor check)	DIAGNOSTIC PROCEDURE 4 (Lifting sensor (front) check)	DIAGNOSTIC PROCEDURE 5 (Lifting sensor (rear) check)	DIAGNOSTIC PROCEDURE 6 (Sliding motor check)	DIAGNOSTIC PROCEDURE 7 (Reclining motor check)
1	No seat system functions operate.	X						
2	Some of the seat system functions do not operate during automatic/manual operation.	Sliding					X	
		Reclining						X
		Lifting (Front)						
		Lifting (Rear)						
3	No functions operate during automatic operation.							
	Some/all functions do not during manual operation.							
4	Some of the seat system functions do not operate during automatic operation.	Sliding	X					
		Reclining		X				
		Lifting (Front)				X		
		Lifting (Rear)					X	
5	No automatic operation functions operate.							
6	Only storing memory function does not operate.							
7	Does not operate during manual operation. (Operates during automatic operation.)	Sliding						
		Reclining						
		Lifting (Front)						
		Lifting (Rear)						
8	Automatic operation cannot be canceled.							
9	Memory indicator does not light up.							

X: Applicable

AUTOMATIC DRIVE POSITIONER

PROCEDURE		Diagnostic procedure						
REFERENCE PAGE		SE-45	SE-46	SE-47	SE-47	SE-48	SE-52	SE-52
SYMPTOM		DIAGNOSTIC PROCEDURE 8 [Lifting motor (front) check]	DIAGNOSTIC PROCEDURE 9 [Lifting motor (rear) check]	DIAGNOSTIC PROCEDURE 10 (Power seat switch check)	DIAGNOSTIC PROCEDURE 11 (Cancel switch check)	DIAGNOSTIC PROCEDURE 12 [Key, ignition (ON and START), A/T device, parking brake, door switch and vehicle speed sensor check]	DIAGNOSTIC PROCEDURE 13 (Seat memory switch check)	DIAGNOSTIC PROCEDURE 14 (Memory indicator check)
1	No seat system functions operate.							
2	Some of the seat system functions do not operate during automatic/manual operation.	Sliding						
		Reclining						
		Lifting (Front)	X					
		Lifting (Rear)		X				
3	No functions operate during automatic operation.			X		X (ON START signal)		
	Some/all functions do not during manual operation.			X				
4	Some of the seat system functions do not operate during automatic operation.	Sliding						
		Reclining						
		Lifting (Front)						
		Lifting (Rear)						
5	No automatic operation functions operate.				X	X		
6	Only storing memory function does not operate.					X (IGN ON signal)	X	
7	Does not operate during manual operation. (Operates during automatic operation.)	Sliding		X				
		Reclining			X			
		Lifting (Front)			X			
		Lifting (Rear)			X			
8	Automatic operation cannot be canceled.				X			
9	Memory indicator does not light up.							X

X: Applicable

A
B
C
D
E
F
G
H
J
K
L
M

SE

AUTOMATIC DRIVE POSITIONER

DIAGNOSTIC PROCEDURE 1

1. POWER SUPPLY CIRCUIT CHECK

1. Turn ignition switch OFF.
2. Disconnect driver seat control unit connector.
3. Check voltage between driver seat control unit connector B324 terminals 1, 11 and ground.

1 (R) – Ground : Battery voltage
11 (R/W) – Ground : Battery voltage

OK or NG

OK >> GO TO 2.

NG >> Check the following

- Circuit breaker
- 50A fusible link (letter **F** , located in fusible link box)
- 10A fuse [No.21 located in fuse block (J/B)]
- Harness for open or short between 50A fusible link, 10A fuse and driver seat control unit

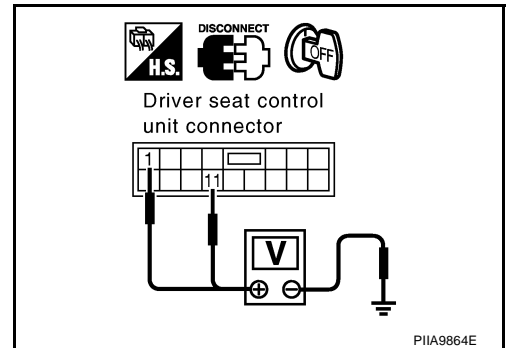

2. GROUND CIRCUIT CHECK

1. Check continuity between driver seat control unit connector B324 terminal 16 and ground.

16 (B/R) – Ground : Continuity should exist.

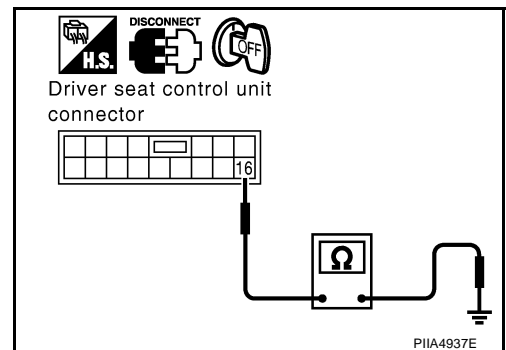

2. Check continuity between driver seat control unit connector B325 terminal 33 and ground.

33 (B) – Ground : Continuity should exist.

OK or NG

OK >> Check the condition of the harness and the connector.

NG >> Repair or replace ground harness

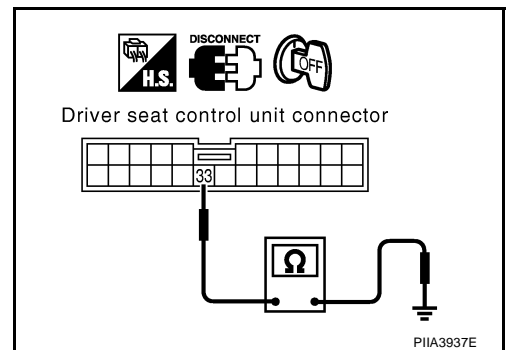

AUTOMATIC DRIVE POSITIONER

DIAGNOSTIC PROCEDURE 2

(Sliding sensor check)

1. CHECK SLIDING SENSOR OUTPUT SIGNAL

1. Turn ignition switch OFF.
2. Sliding switch operate, check signal between driver seat control unit connector and ground with oscilloscope.

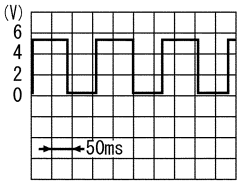
Connector	Terminals (Wire color)		Sliding switch condition	Signal (Reference value)
	(+)	(-)		
B325	18 (G)	Ground	Operate	 <p style="text-align: right; font-size: small;">SIIA0690J</p>

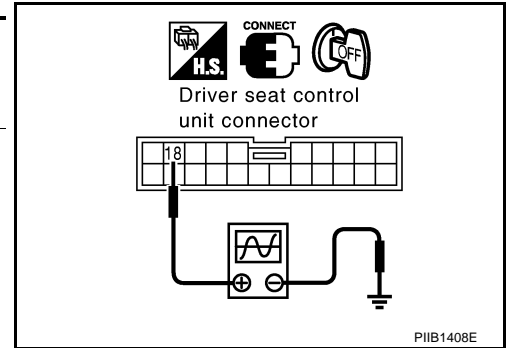

OK or NG

- OK >> Sliding sensor is OK.
- NG >> GO TO 2.

2. CHECK SLIDING SENSOR OPEN CIRCUIT

1. Disconnect driver seat control unit connector and sliding motor connector.
2. Check harness continuity between driver seat control unit connector B325 terminals 18, 28 and sliding motor connector B322 terminals 18, 28.

- 18 (G) – 18 (G) : Continuity should exist.**
- 28 (B/W) – 28 (B/W) : Continuity should exist.**

OK or NG

- OK >> GO TO 3.
- NG >> Repair or replace harness.

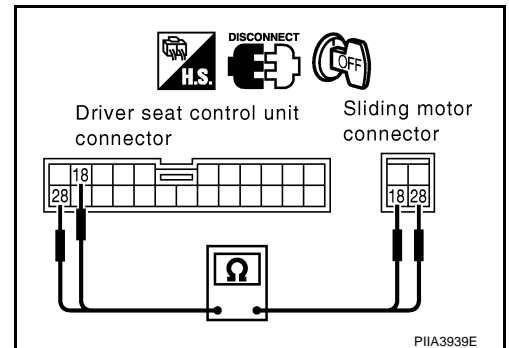

3. CHECK SLIDING SENSOR SHORT CIRCUIT

Check harness continuity between driver seat control unit connector B325 terminals 18, 28 and ground.

- 18 (G) – Ground : Continuity should not exist.**
- 28 (B/W) – Ground : Continuity should not exist.**

OK or NG

- OK >> Replace sliding motor (sliding sensor).
- NG >> Repair or replace harness.

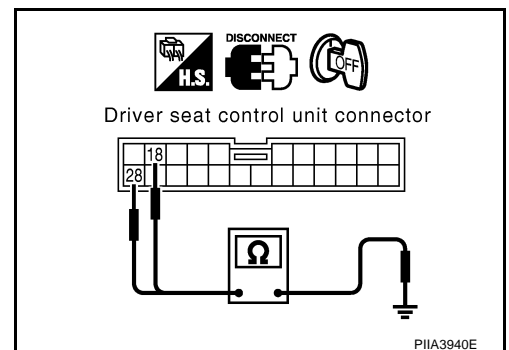

AUTOMATIC DRIVE POSITIONER

DIAGNOSTIC PROCEDURE 3

(Reclining sensor check)

1. CHECK RECLINING SENSOR OUTPUT SIGNAL

1. Turn ignition switch OFF.
2. Reclining switch operate, check voltage between driver seat control unit connector and ground with oscilloscope.

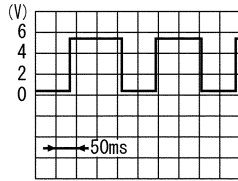
Connector	Terminals (Wire color)		Reclining switch condition	Signal (Reference value)
	(+)	(-)		
B325	29 (G/L)	Ground	Operate	 <p style="text-align: right;">SIIA0692J</p>

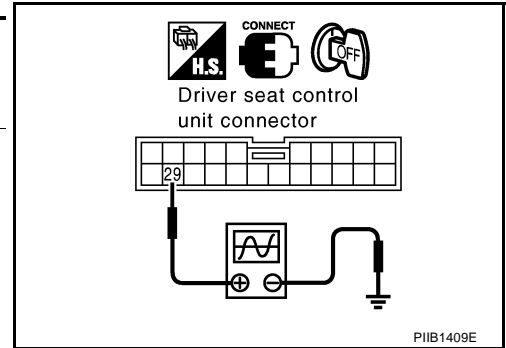

OK or NG

- OK >> Reclining sensor is OK.
 NG >> GO TO 2.

2. CHECK RECLINING SENSOR OPEN CIRCUIT

1. Disconnect driver seat control unit connector and reclining motor connector.
2. Check harness continuity between driver seat control unit connector B325 terminals 28, 29 and reclining motor connector B323 terminals 28, 29.

- 28 (B/W) – 28 (B/W) : Continuity should exist.**
29 (G/L) – 29 (G/L) : Continuity should exist.

OK or NG

- OK >> GO TO 3.
 NG >> Repair or replace harness.

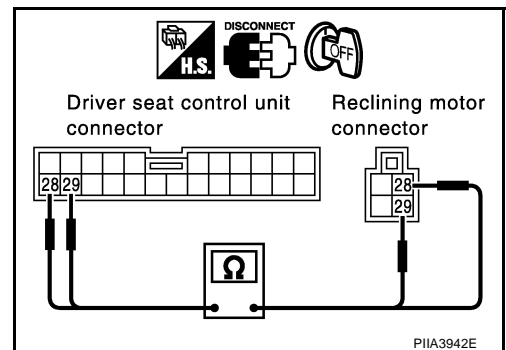

3. CHECK RECLINING SENSOR SHORT CIRCUIT

Check harness continuity between driver seat control unit connector B325 terminals 28, 29 and ground.

- 28 (B/W) – Ground : Continuity should not exist.**
29 (G/L) – Ground : Continuity should not exist.

OK or NG

- OK >> Replace reclining motor (reclining sensor).
 NG >> Repair or replace harness.

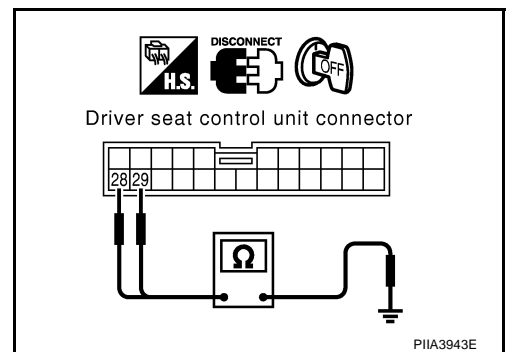

AUTOMATIC DRIVE POSITIONER

DIAGNOSTIC PROCEDURE 4

[Lifting sensor (front) check]

1. CHECK LIFTING SENSOR (FRONT) OUTPUT SIGNAL

1. Turn ignition switch OFF.
2. Lifting switch (front) operate, check signal between driver seat control unit connector and ground with oscilloscope.

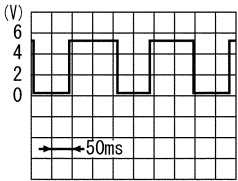
Connector	Terminals (Wire color)		Lifting switch (front) condition	Signal (Reference value)
	(+)	(-)		
B325	19 (G/Y)	Ground	Operate	 <p>SIIA0691J</p>

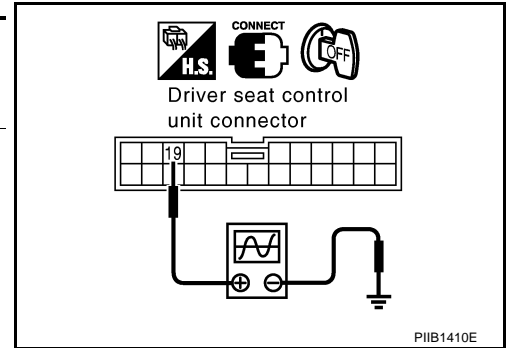

OK or NG

- OK >> Lifting sensor (front) is OK.
 NG >> GO TO 2.

2. CHECK LIFTING SENSOR (FRONT) OPEN CIRCUIT

1. Disconnect driver seat control unit connector and front lifting motor connector.
2. Check harness continuity between driver seat control unit connector B325 terminals 19, 28 and front lifting motor connector B330 terminals 19, 28.

- 19 (G/Y) – 19 (G/Y) : Continuity should exist.**
28 (B/W) – 28 (B/W) : Continuity should exist.

OK or NG

- OK >> GO TO 3.
 NG >> Repair or replace harness.

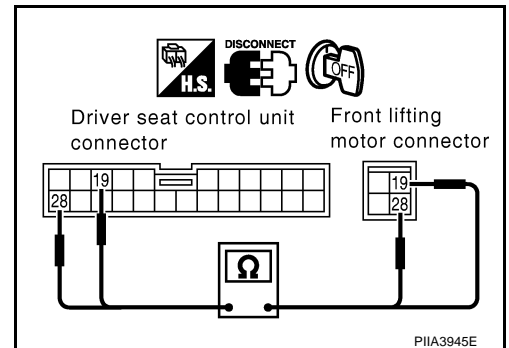

3. CHECK LIFTING SENSOR (FRONT) SHORT CIRCUIT

Check harness continuity between driver seat control unit connector B325 terminals 19, 28 and ground.

- 19 (G/Y) – Ground : Continuity should not exist.**
28 (B/W) – Ground : Continuity should not exist.

OK or NG

- OK >> Replace lifting motor (front) [lifting sensor (front)].
 NG >> Repair or replace harness.

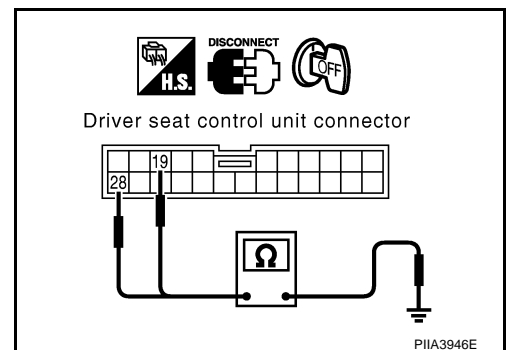

AUTOMATIC DRIVE POSITIONER

DIAGNOSTIC PROCEDURE 5

[Lifting sensor (rear) check]

1. CHECK LIFTING SENSOR (REAR) OUTPUT SIGNAL

1. Turn ignition switch OFF.
2. Lifting switch (rear) operate, check signal between driver seat control unit connector and ground with oscilloscope.

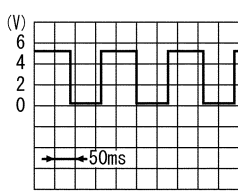
Con- nector	Terminals (Wire color)		Lifting switch (rear) condition	Signal (Reference value)
	(+)	(-)		
B325	30 (G/W)	Ground	Operate	 <p style="text-align: right; font-size: small;">SIIA0693J</p>

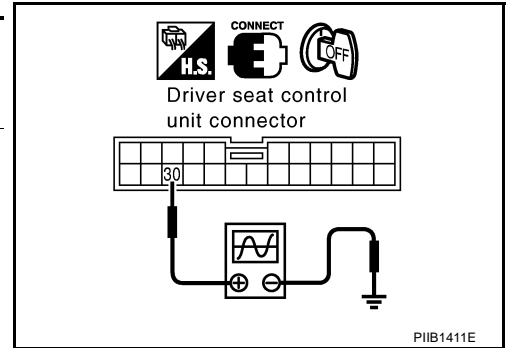

OK or NG

- OK >> Lifting sensor (rear) is OK.
- NG >> GO TO 2.

2. CHECK LIFTING SENSOR (REAR) OPEN CIRCUIT

1. Disconnect driver seat control unit connector and rear lifting motor connector.
2. Check harness continuity between driver seat control unit connector B325 terminals 28, 30 and rear lifting motor connector B331 terminals 28, 30.

- 28 (B/W) – 28 (B/W) : Continuity should exist.**
- 30 (G/W) – 30 (G/W) : Continuity should exist.**

OK or NG

- OK >> GO TO 3.
- NG >> Repair or replace harness.

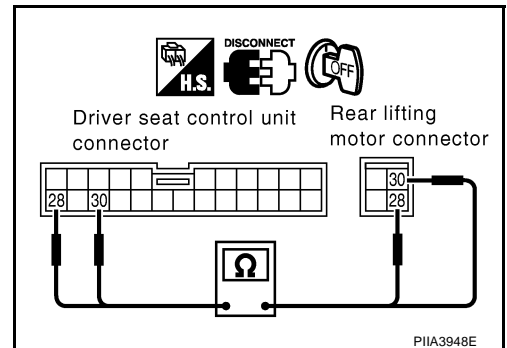

3. CHECK LIFTING SENSOR (REAR) SHORT CIRCUIT

Check harness continuity between driver seat control unit connector B325 terminals 28, 30 and ground.

- 28 (B/W) – Ground : Continuity should not exist.**
- 30 (G/W) – Ground : Continuity should not exist.**

OK or NG

- OK >> Replace lifting motor (rear) [lifting sensor (rear)].
- NG >> Repair or replace harness.

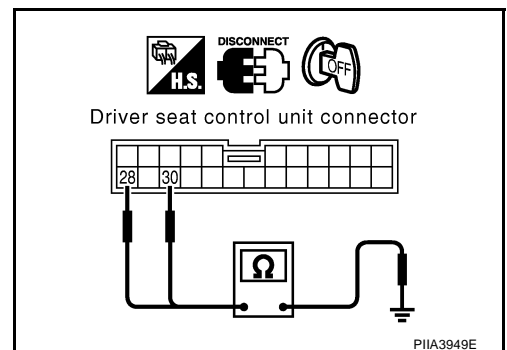

AUTOMATIC DRIVE POSITIONER

DIAGNOSTIC PROCEDURE 6

(Sliding motor check)

1. CHECK OUTPUT SIGNAL TO SLIDING MOTOR

1. Turn ignition switch OFF.
2. Disconnect sliding motor connector.
3. Sliding switch operate, check voltage between sliding motor connector and ground.

Connector	Terminals (wire color)		Sliding switch condition	Voltage (V) (Approx.)
	(+)	(-)		
B322	3 (G)	Ground	FORWARD	Battery voltage
			Other than above	0
	10 (G/R)		BACKWARD	Battery voltage
			Other than above	0

OK or NG

- OK >> Replace sliding motor.
 NG >> GO TO 2.

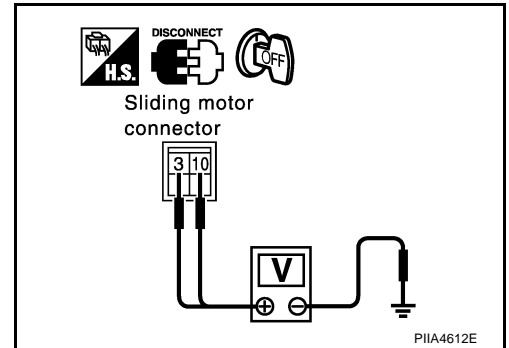

2. CHECK SLIDING MOTOR HARNESS

1. Disconnect driver seat control unit connector.
2. Check continuity between driver seat control unit connector B324 terminals 3, 10 and sliding motor connector B322 terminals 3, 10.

3 (G) – 3 (G) : Continuity should exist.

10 (G/R) – 10 (G/R) : Continuity should exist.

3. Check continuity between driver seat control unit connector B324 terminals 3, 10 and ground.

3 (G) – Ground : Continuity should not exist.

10 (G/R) – Ground : Continuity should not exist.

OK or NG

- OK >> Replace driver seat control unit.
 NG >> Repair or replace harness.

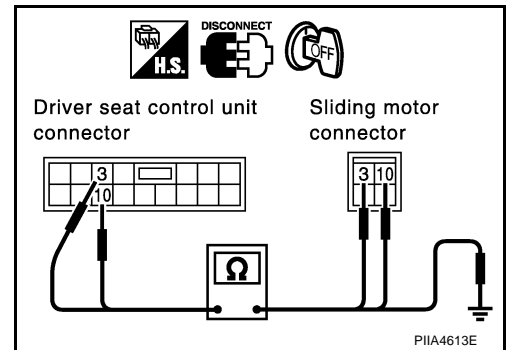

A
B
C
D
E
F
G
H
SE
J
K
L
M

AUTOMATIC DRIVE POSITIONER

DIAGNOSTIC PROCEDURE 7

(Reclining motor check)

1. CHECK OUTPUT SIGNAL TO RECLINING MOTOR

1. Turn ignition switch OFF.
2. Disconnect reclining motor connector.
3. Reclining switch operate, check voltage between reclining motor connector and ground.

Connector	Terminals (wire color)		Reclining switch condition	Voltage (V) (Approx.)
	(+)	(-)		
B323	4 (G/L)	Ground	FORWARD	Battery voltage
			Other than above	0
	12 (G/Y)		BACKWARD	Battery voltage
			Other than above	0

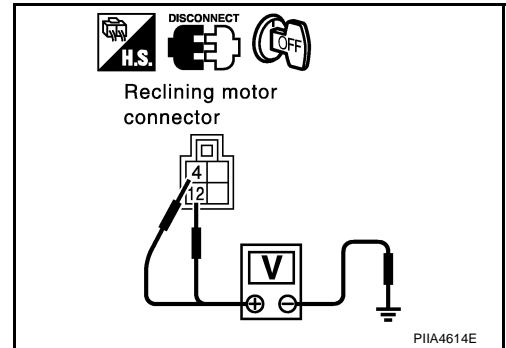

OK or NG

- OK >> Replace reclining motor.
 NG >> GO TO 2.

2. CHECK RECLINING MOTOR HARNESS

1. Disconnect driver seat control unit connector.
2. Check continuity between driver seat control unit connector B324 terminals 4, 12 and reclining motor connector B323 terminals 4, 12.

4 (G/L) – 4 (G/L) : Continuity should exist.
12 (G/Y) – 12 (G/Y) : Continuity should exist.

3. Check continuity between driver seat control unit connector B324 terminals 4, 12 and ground.

4 (G/L) – Ground : Continuity should not exist.
12 (G/Y) – Ground : Continuity should not exist.

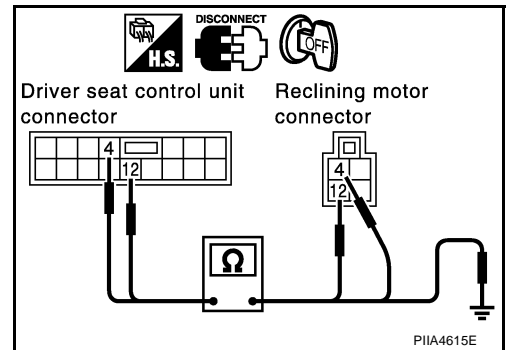

OK or NG

- OK >> Replace driver seat control unit.
 NG >> Repair or replace harness.

AUTOMATIC DRIVE POSITIONER

DIAGNOSTIC PROCEDURE 8

[Lifting motor (front) check]

1. CHECK OUTPUT SIGNAL TO LIFTING MOTOR (FRONT)

1. Turn ignition switch OFF.
2. Disconnect lifting motor (front) connector.
3. Lifting switch (front) operate, check voltage between lifting motor (front) connector and ground.

Connector	Terminals (wire color)		Lifting switch (front) condition	Voltage (V) (Approx.)
	(+)	(-)		
B330	13 (G/Y)	Ground	UP	Battery voltage
			Other than above	0
	5 (G/L)		DOWN	Battery voltage
			Other than above	0

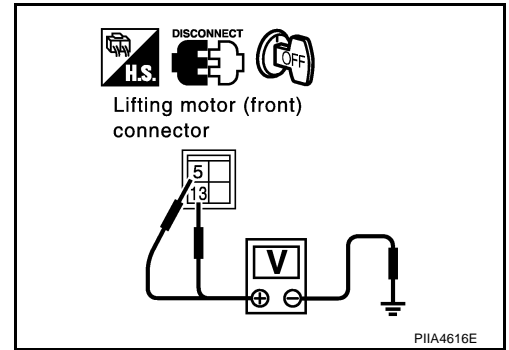

OK or NG

- OK >> Replace lifting motor (front).
 NG >> GO TO 2.

2. CHECK LIFTING MOTOR (FRONT) HARNESS

1. Disconnect driver seat control unit connector.
2. Check continuity between driver seat control unit connector B324 terminals 5, 13 and lifting motor (front) connector B330 terminals 5, 13.

5 (G/L) – 5 (G/L) : Continuity should exist.

13 (G/Y) – 13 (G/Y) : Continuity should exist.

3. Check continuity between driver seat control unit connector B324 terminals 5, 13 and ground.

5 (G/L) – Ground : Continuity should not exist.

13 (G/Y) – Ground : Continuity should not exist.

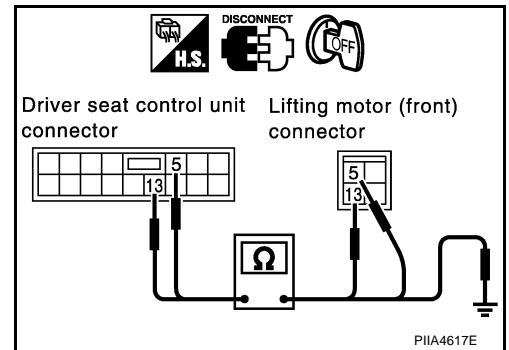

OK or NG

- OK >> Replace driver seat control unit.
 NG >> Repair or replace harness.

AUTOMATIC DRIVE POSITIONER

DIAGNOSTIC PROCEDURE 9

[Lifting motor (rear) check]

1. CHECK OUTPUT SIGNAL TO LIFTING MOTOR (REAR)

1. Turn ignition switch OFF.
2. Disconnect lifting motor (rear) connector.
3. Lifting switch (rear) operate, check voltage between lifting motor (rear) connector and ground.

Connector	Terminals (wire color)		Lifting switch (rear) condition	Voltage (V) (Approx.)
	(+)	(-)		
B331	6 (G/W)	Ground	UP	Battery voltage
			Other than above	0
	7 (G/B)		DOWN	Battery voltage
			Other than above	0

OK or NG

- OK >> Replace lifting motor (rear).
 NG >> GO TO 2.

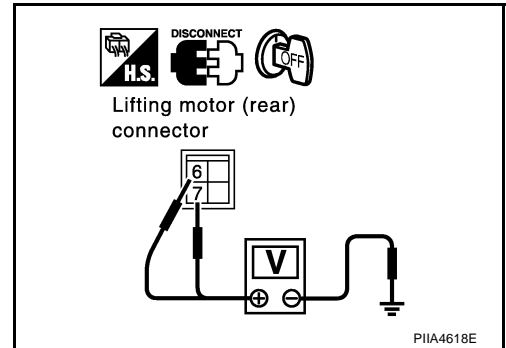

2. CHECK LIFTING MOTOR (REAR) HARNESS

1. Disconnect driver seat control unit connector.
2. Check continuity between driver seat control unit connector B324 terminals 6, 7 and lifting motor (rear) connector B331 terminals 6, 7.

6 (G/W) – 6 (G/W) : Continuity should exist.

7 (G/B) – 7 (G/B) : Continuity should exist.

3. Check continuity between driver seat control unit connector B324 terminals 6, 7 and ground.

6 (G/W) – Ground : Continuity should not exist.

7 (G/B) – Ground : Continuity should not exist.

OK or NG

- OK >> Replace driver seat control unit.
 NG >> Repair or replace harness.

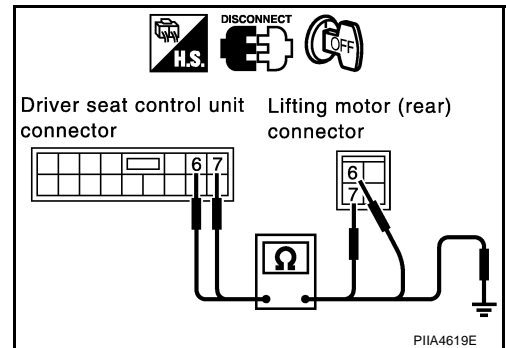

AUTOMATIC DRIVE POSITIONER

DIAGNOSTIC PROCEDURE 10

(Power seat switch check)

1. CHECK POWER SEAT SWITCH

1. Turn ignition switch OFF.
2. Disconnect power seat switch connector.
3. Power seat switch operate, check continuity between power seat switch connector B326 terminals 3, 4, 5, 6 and 1.

Connector	Terminals	Power seat switch condition	Continuity	
B326	5	Sliding	FORWARD	Yes
	6		BACKWARD	
	3	Reclining	FORWARD	
	4		BACKWARD	

4. Check continuity between power seat switch terminal connector B327 terminals 7 and 9, 10, 11, 12.

Connector	Terminals	Power seat switch condition	Continuity	
B327	12	Lifting (front)	UP	Yes
	11		DOWN	
	10	Lifting (rear)	UP	
	9		DOWN	

OK or NG

- OK >> Check the following.
- Ground circuit for power seat switch
 - Harness for open or short between driver seat control unit and power seat switch
- NG >> Replace power seat switch.

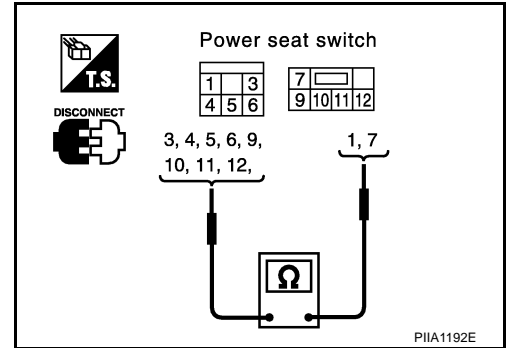

DIAGNOSTIC PROCEDURE 11

(Cancel switch check)

1. CHECK CANCEL SWITCH

1. Turn ignition switch OFF.
2. Disconnect seat memory switch (cancel switch) connector B328.
3. Check continuity between seat memory switch (cancel switch) connector B328 terminals 8 and 33.

Connector	Terminals	Cancel switch condition	Continuity	
B328	8	33	ON	Yes
			OFF	No

OK or NG

- OK >> Check the following.
- Ground circuit for seat memory (cancel switch)
 - Harness for open or short between driver seat control unit and seat memory switch (cancel switch)
- NG >> Replace seat memory switch (cancel switch).

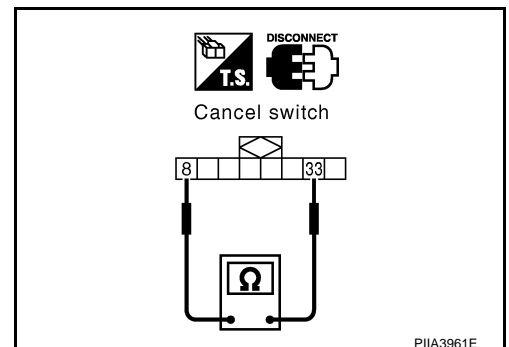

AUTOMATIC DRIVE POSITIONER

DIAGNOSTIC PROCEDURE 12

(Check Key switch, A/T device (park position switch), Parking brake switch, Door switch and Vehicle speed signal)

1. CHECK KEY SWITCH INPUT SIGNAL (A/T MODELS)

Check voltage between driver seat control unit connector and ground.

Connector	Terminals (Wire color)		Key condition	Voltage (V) (Approx.)
	(+)	(-)		
B324	2 (L)	Ground	: Inserted	Battery voltage
			: Removed	0

OK or NG

- OK >> Key switch is OK. GO TO 4.
 NG >> GO TO 2

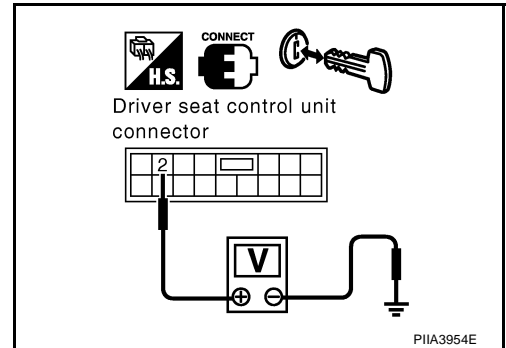

2. CHECK KEY SWITCH (A/T MODELS)

1. Turn ignition switch OFF.
2. Disconnect key switch connector.
3. Check continuity between key switch connector M25 terminals 1 and 2.

Connector	Terminals		Key condition	Continuity
M25	1	2	: Inserted	Yes
			: Removed	No

OK or NG

- OK >> Check the following.
- 10A fuse [No. 21, located in fuse block (J/B)]
 - Harness for open or short between key switch and fuse
 - Harness for open or short between driver seat control unit and key switch
- NG >> Replace key switch.

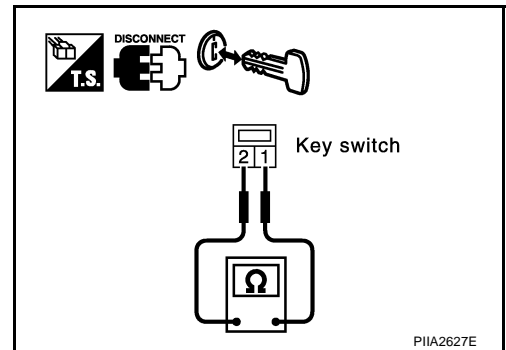

3. CHECK IGNITION SWITCH INPUT SIGNAL (ON AND START)

Check voltage between driver seat control unit connector and ground.

Connector	Terminals (Wire color)		Ignition switch position	Voltage (V) (Approx.)
	(+)	(-)		
B325	20 (R/B)	Ground	ON or START	Battery voltage
	31 (R/L)		START	

OK or NG

- OK >> ● A/T models GO TO 4.
 ● M/T models GO TO 6.
- NG >> Check the following.
- 10A fuse [No. 9, located in fuse block (J/B)]
 - 10A fuse [No. 12, located in fuse block (J/B)]
 - Harness for open or short between driver seat control unit and fuse

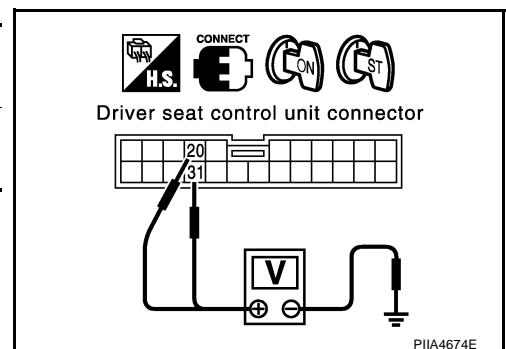

AUTOMATIC DRIVE POSITIONER

4. CHECK A/T DEVICE (PARK POSITION SWITCH) INPUT SIGNAL (A/T MODELS)

Check voltage between driver seat control unit connector and ground.

Connector	Terminals (Wire color)		Condition	Voltage (V) (Approx.)
	(+)	(-)		
B325	21 (L/Y)	Ground	Selector lever is in P position	0
			Other than above	Battery voltage

OK or NG

- OK >> A/T device (park position switch) is OK, and GO TO 8.
 NG >> GO TO 5.

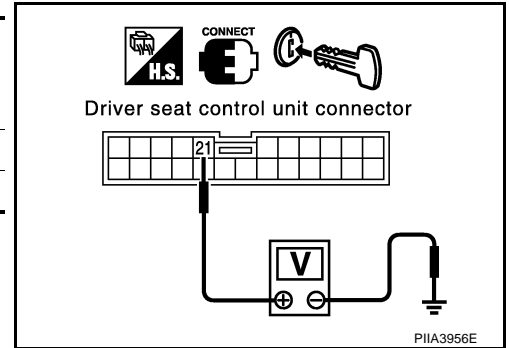

5. CHECK A/T DEVICE (PARK POSITION SWITCH) (A/T MODELS)

1. Turn ignition switch OFF.
2. Disconnect A/T device connector.
3. Check continuity between A/T device (Park position switch) connector M47 terminal 1 and 3.

Connector	Terminals		Condition	Continuity
M47	1	3	Selector lever is in P position	Yes
			Other than above	No

OK or NG

- OK >> Check the following.
- A/T device (Park position switch) ground circuit
 - Harness for open or short between driver seat control unit and A/T device (Park position switch)
- NG >> Replace A/T device (Park position switch)

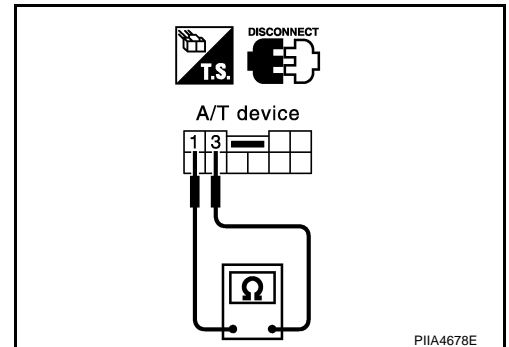

6. CHECK PARKING BRAKE SWITCH INPUT SIGNAL (M/T MODELS)

Check voltage between driver seat control unit connector and ground.

Connector	Terminals (Wire color)		Condition	Voltage (V) (Approx.)
	(+)	(-)		
B325	21 (L/Y)	Ground	Parking brake : Applied	0
			: Released	Battery voltage

OK or NG

- OK >> Parking brake is OK. GO TO 10.
 NG >> GO TO 7.

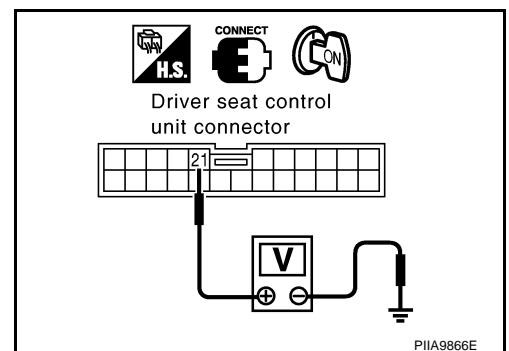

AUTOMATIC DRIVE POSITIONER

7. CHECK PARKING BRAKE SWITCH (M/T MODELS)

1. Disconnect parking brake switch connector.
2. Check continuity between parking brake switch connector B37 terminal 1 and ground part of parking brake switch.

Connector	Terminals		Parking brake switch condition	Continuity
B37	1	Ground part of parking brake switch	Released	Yes
			Pushed	No

OK or NG

- OK >> Parking brake switch is OK, and check the following.
- Parking brake switch case ground
 - Harness for open or short between driver seat control unit and parking brake switch
- NG >> Replace parking brake switch.

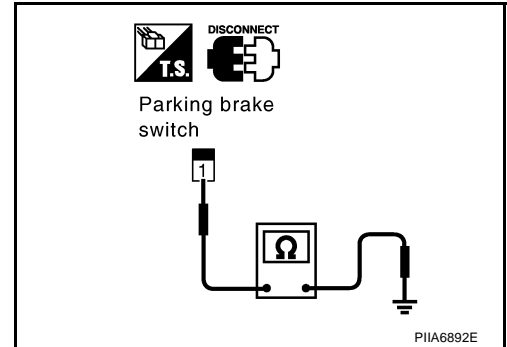

8. CHECK FRONT DOOR SWITCH DRIVER SIDE INPUT SIGNAL (A/T MODELS)

Check voltage between driver seat control unit connector and ground.

Connector	Terminals (Wire color)		Condition	Voltage (V) (Approx.)
	(+)	(-)		
B324	9 (L/B)	Ground	Driver door is open	0
			Driver door is close	Battery voltage

OK or NG

- OK >> Front door switch driver side is OK. GO TO 11.
- NG >> GO TO 9.

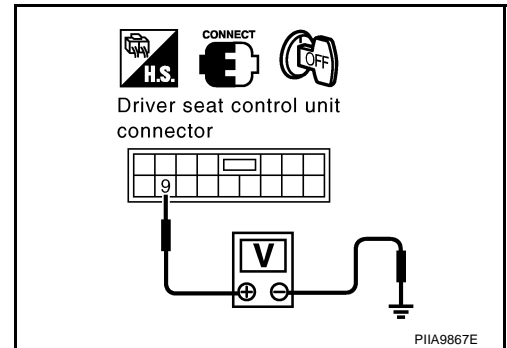

9. CHECK FRONT DOOR SWITCH DRIVER SIDE (A/T MODELS)

1. Disconnect front door switch driver side connector.
2. Check continuity between front door switch driver side connector B17 terminal 1 and ground part of driver door switch.

Connector	Terminals		Door switch condition	Continuity
B17	1	Ground part of parking brake switch	Released	Yes
			Pushed	No

OK or NG

- OK >> Check the following.
- Front door switch driver side case ground
 - Harness for open or short between driver seat control unit and front door switch driver side
- NG >> Replace driver door switch.

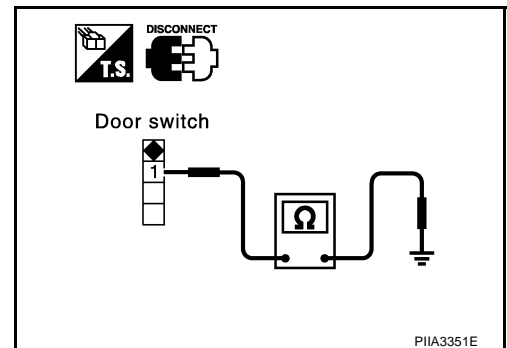

10. CHECK VEHICLE SPEED METER

Does speedometer operate normally?

Yes or No

- Yes >> GO TO 11.
- No >> Check combination meter. Refer to [DI-4, "COMBINATION METERS"](#).

AUTOMATIC DRIVE POSITIONER

11. CHECK VEHICLE SPEED SIGNAL

1. Disconnect driver seat control unit connector.
2. Turn ignition switch ON.
3. Check the signal between driver seat control unit connector and ground with oscilloscope.

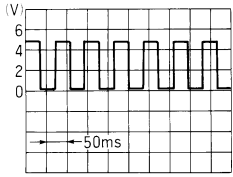
Connector	Terminal (Wire color)		Condition	Signal (Reference value)
	(+)	(-)		
B325	32 (Y/B)	Ground	vehicle speed is approx 40k m/h (25MPH).	 <p style="text-align: right; font-size: small;">ELF1080D</p>

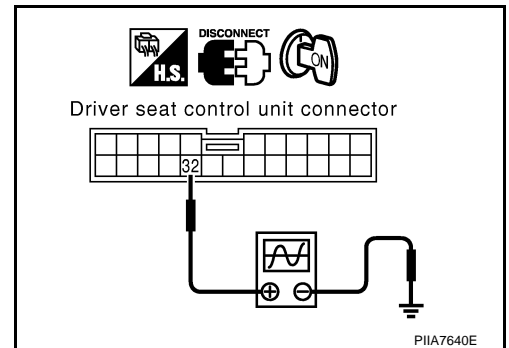

OK or NG

- OK >> Check the condition of the driver seat control unit connector. If check is OK, replace driver seat control unit.
- NG >> GO TO 12.

12. CHECK VEHICLE SPEED SIGNAL CIRCUIT HARNESS

1. Turn ignition switch OFF.
2. Disconnect combination meter connector.
3. Check continuity between combination meter connector M19 terminal 19 and driver seat control unit connector B325 terminal 32.

19 (G/W) – 32 (Y/B) : Continuity should exist.

4. Check continuity between combination meter connector M19 terminal 19 and ground.

19 (G/W) – Ground : Continuity should not exist.

OK or NG

- OK >> GO TO 13.
- NG >> Repair or replace harness between combination meter and driver seat control unit.

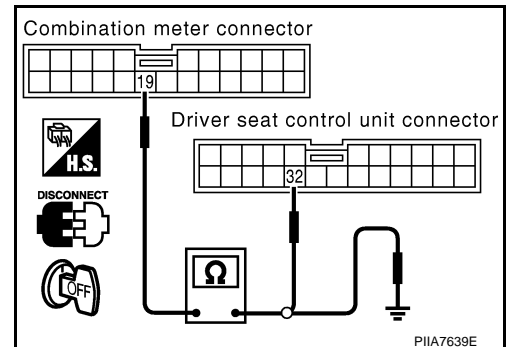

13. CHECK VEHICLE SPEED SIGNAL PULL UP VOLTAGE

1. Connect combination meter connector.
2. Turn ignition switch ON.
3. Check voltage between driver seat control unit connector B325 terminal 32 and ground.

32 (Y/B) – Ground : Approx. 5V

OK or NG

- OK >> Check the condition of the harness and connector.
- NG >> Repair combination meter.

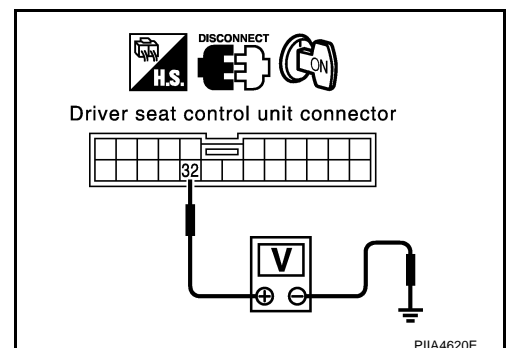

AUTOMATIC DRIVE POSITIONER

DIAGNOSTIC PROCEDURE 13

(Seat memory switch check)

1. CHECK SEAT MEMORY SWITCH

1. Turn ignition switch OFF.
2. Disconnect seat memory switch connector.
3. Check continuity between seat memory switch connector M328 terminals 22, 34, 35 and 33.

Connector	Terminals	Switch condition	Continuity	
B328	22	Memory switch-1	ON	Yes
			OFF	No
	35	Memory switch-2	ON	Yes
			OFF	No
	34	Set switch	ON	Yes
			OFF	No

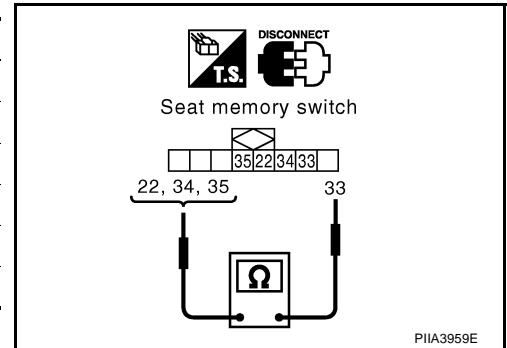

OK or NG

OK >> Check the following.

- Ground circuit for seat memory switch
- Harness for open or short between driver seat control unit and seat memory switch

NG >> Replace seat memory switch.

DIAGNOSTIC PROCEDURE 14

(Memory indicator check)

1. CHECK POWER SUPPLY CIRCUIT FOR INDICATOR LAMP

1. Turn ignition switch OFF.
2. Disconnect seat memory switch connector.
3. Check voltage between seat memory connector B328 switch terminal 11 and ground.

11 (R/W) – Ground : Battery voltage

OK or NG

OK >> GO TO 2.

NG >> Check the following.

- 10A fuse [No. 21 located in the fuse block (J/B)]
- Harness for open or short between fuse and indicator lamp

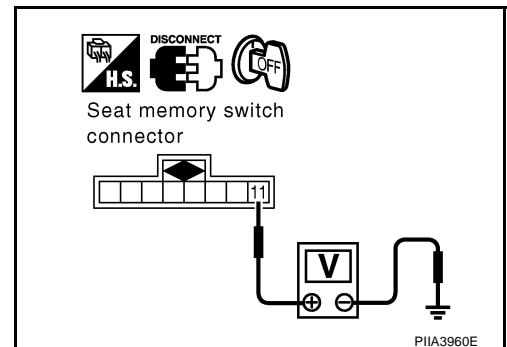

2. CHECK INDICATOR LAMP HARNESS

1. Disconnect driver seat control unit connector.
2. Check continuity between seat memory switch connector B328 terminals 23, 36 and driver seat control unit connector B325 terminals 23, 36.

23 (Y/W) – 23 (Y/W) : Continuity should exist.

36 (Y/G) – 36 (Y/G) : Continuity should exist.

OK or NG

OK >> Replace seat memory switch.

NG >> Repair or replace harness.

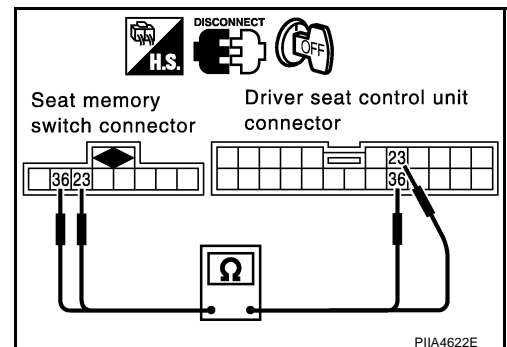

POWER SEAT

PFP:87016

POWER SEAT

Wiring Diagram-SEAT- for Driver Seat

AI/S0008C

SE-SEAT-01

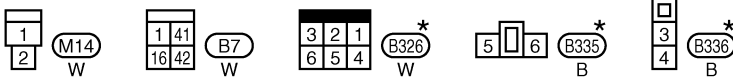
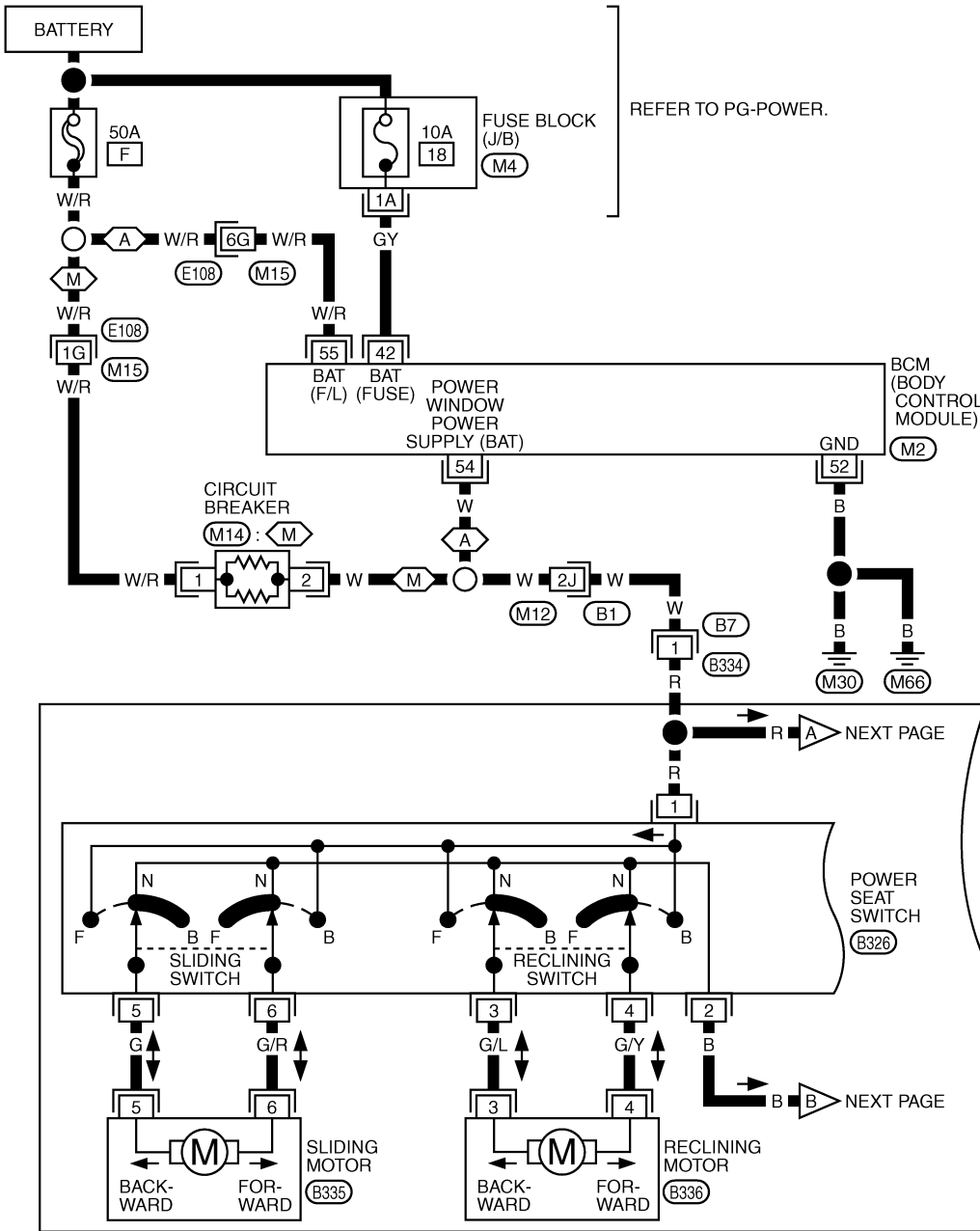

*: THIS CONNECTOR IS NOT SHOWN IN "HARNESS LAYOUT", PG SECTION.

REFER TO THE FOLLOWING.
 (E108), (B1) -SUPER MULTIPLE JUNCTION (SMJ)
 (M4) -FUSE BLOCK-JUNCTION BOX (J/B)
 (M2) -ELECTRICAL UNITS

TIWT0663E

POWER SEAT

SE-SEAT-02

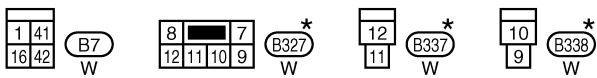
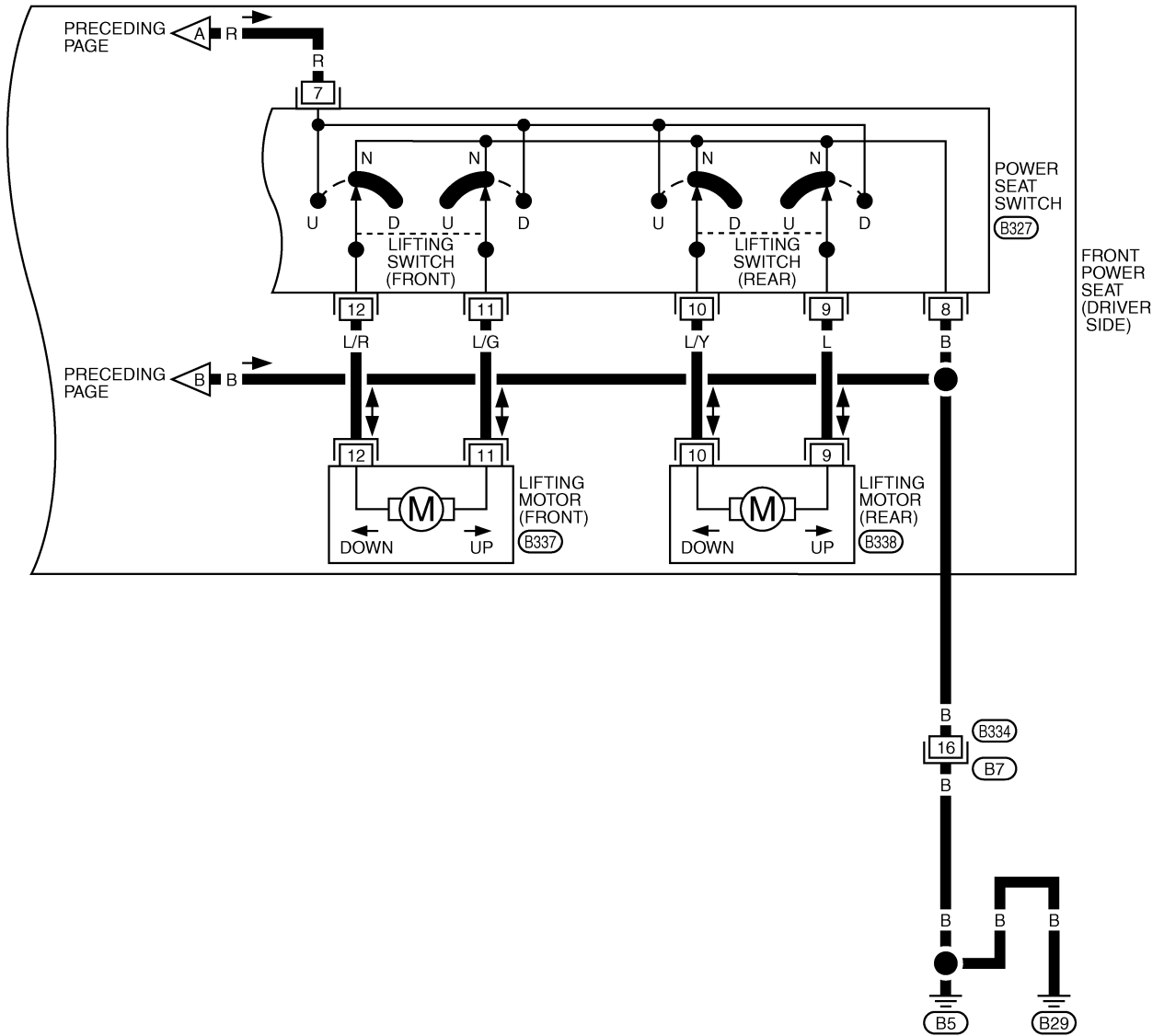

*: THIS CONNECTOR IS NOT SHOWN IN "HARNESS LAYOUT", PG SECTION.

TIWT0383E

POWER SEAT

Wiring Diagram-SEAT- for Passenger Seat

AIS000B6

SE-SEAT-03

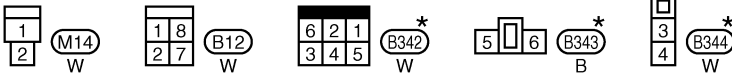
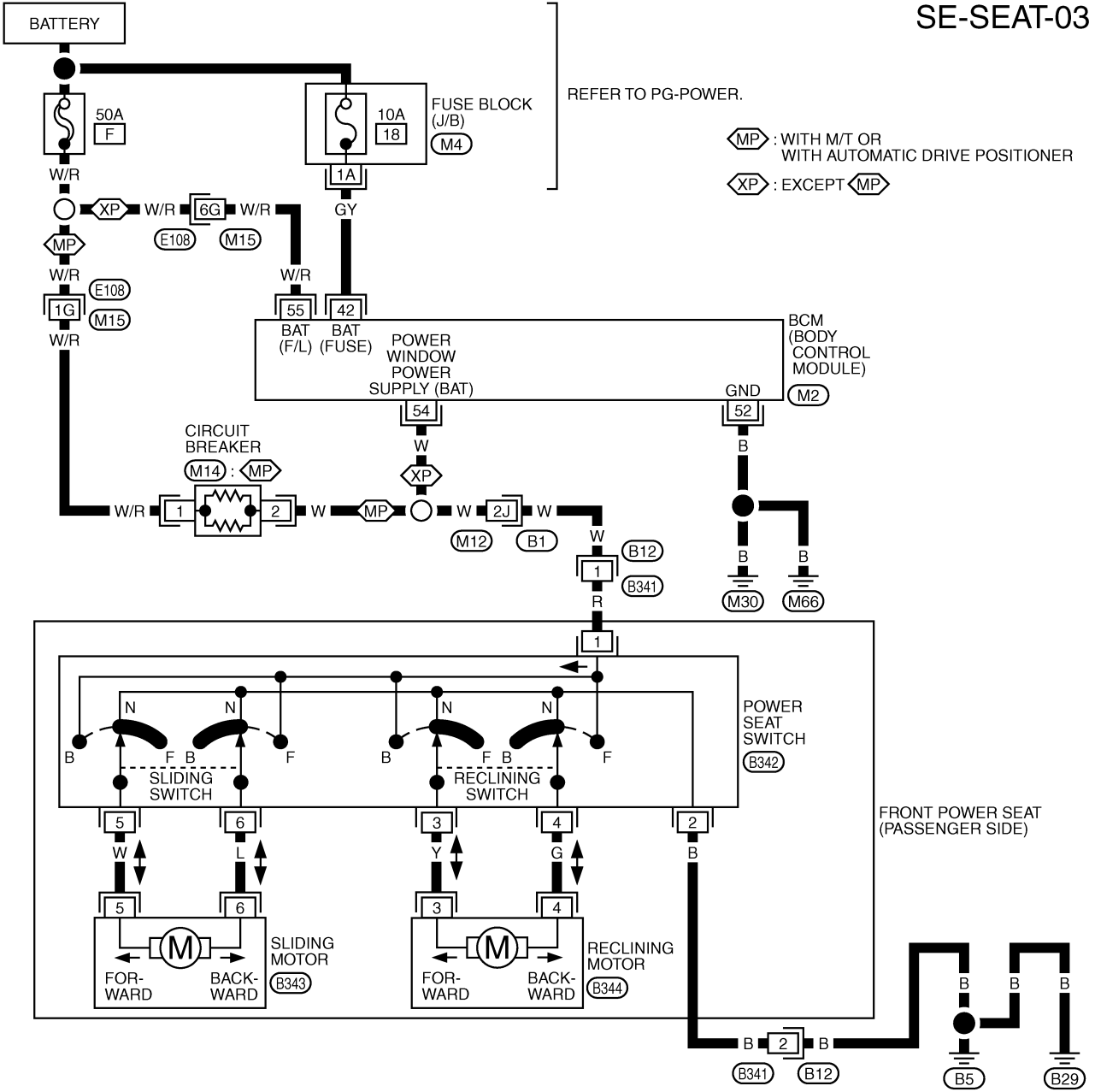

REFER TO THE FOLLOWING.

(E108), (B1) -SUPER MULTIPLE JUNCTION (SMJ)

(M4) -FUSE BLOCK-JUNCTION BOX (J/B)

(M2) -ELECTRICAL UNITS

*: THIS CONNECTOR IS NOT SHOWN IN "HARNESS LAYOUT", PG SECTION.

HEATED SEAT

PFP:87335

HEATED SEAT

Description

AIS0008D

- When handling seat, be extremely careful not to scratch heating unit.
- To replace heating unit, seat trim and pad should be separated.
- Do not use any organic solvent, such as thinner, benzene, alcohol, etc. to clean trims.

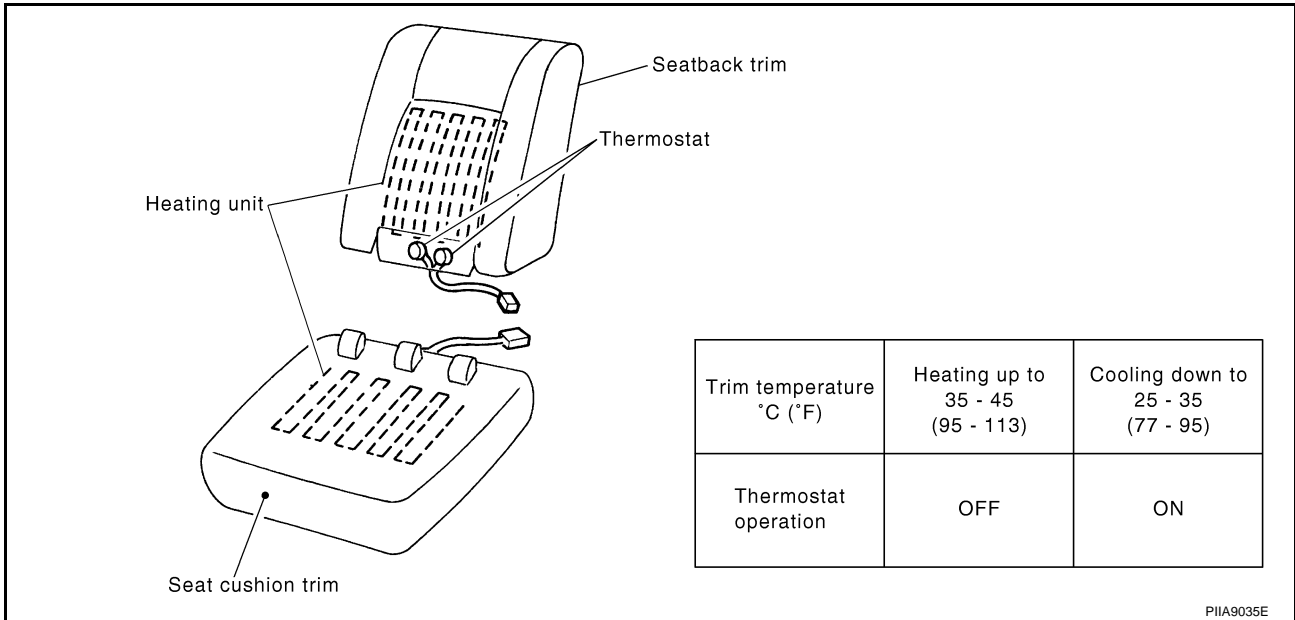

HEATED SEAT

Schematic

AIS0008E

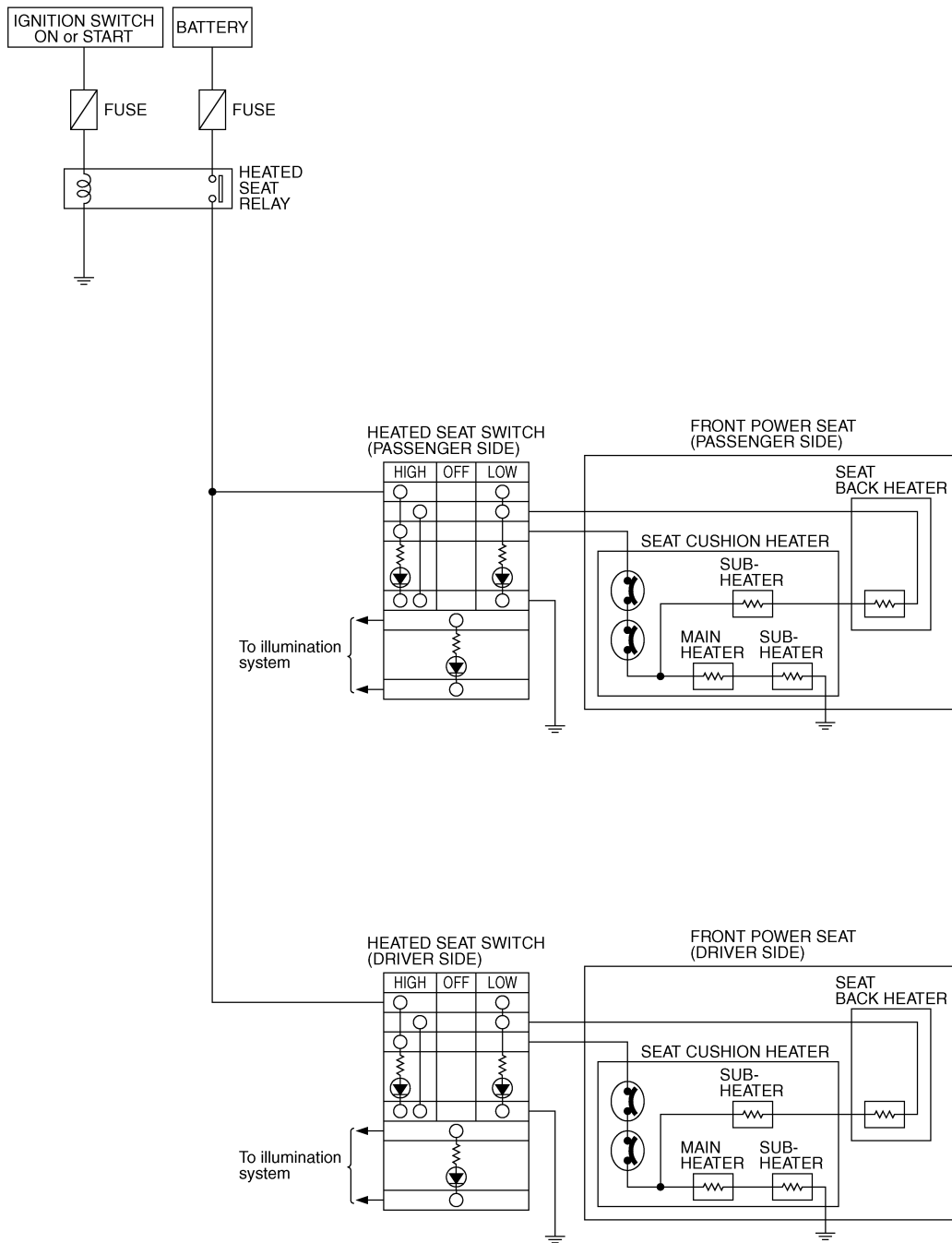

A
B
C
D
E
F
G
H
SE
J
K
L
M

TIWT0343E

HEATED SEAT

Wiring Diagram – HSEAT – / For A/T Models

AIS0008F

SE-HSEAT-01

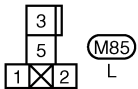
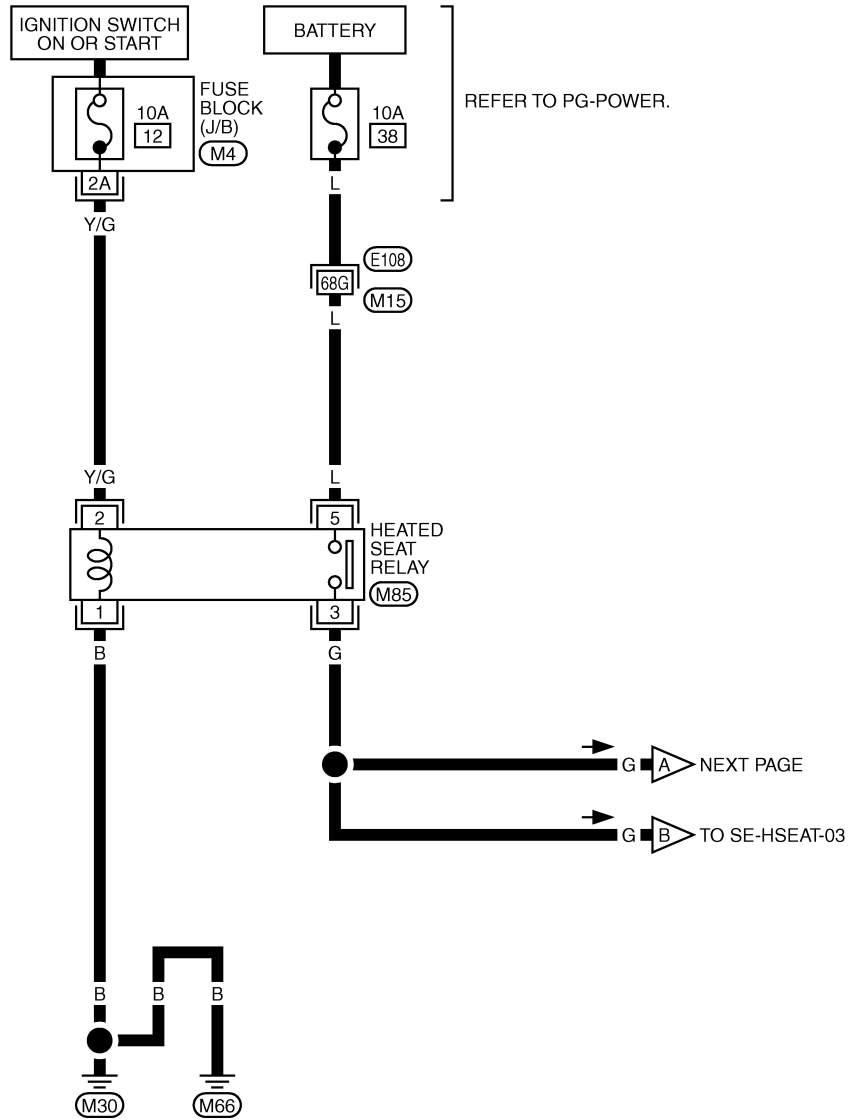

REFER TO THE FOLLOWING.

- (E108) -SUPER MULTIPLE JUNCTION (SMJ)
- (M4) -FUSE BLOCK-JUNCTION BOX (J/B)

TIWT0919E

HEATED SEAT

SE-HSEAT-02

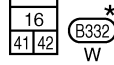
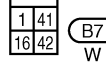
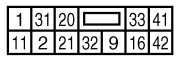
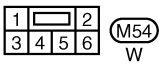
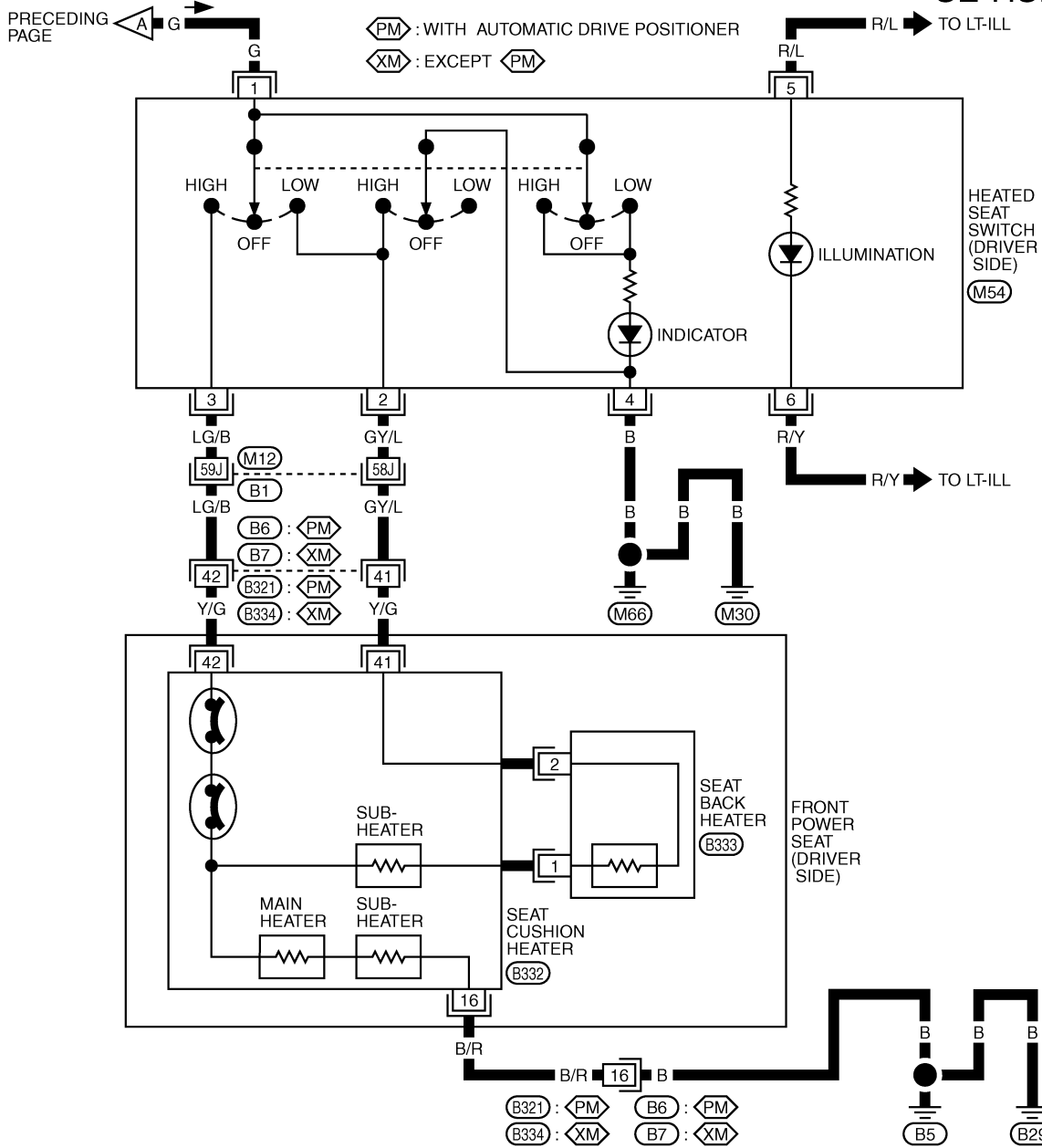

REFER TO THE FOLLOWING.
 (B1) -SUPER MULTIPLE JUNCTION (SMJ)

*: THIS CONNECTOR IS NOT SHOWN IN "HARNESS LAYOUT", PG SECTION.

TIWT0920E

HEATED SEAT

Wiring Diagram – HSEAT – / For M/T Models

AIS003L0

SE-HSEAT-04

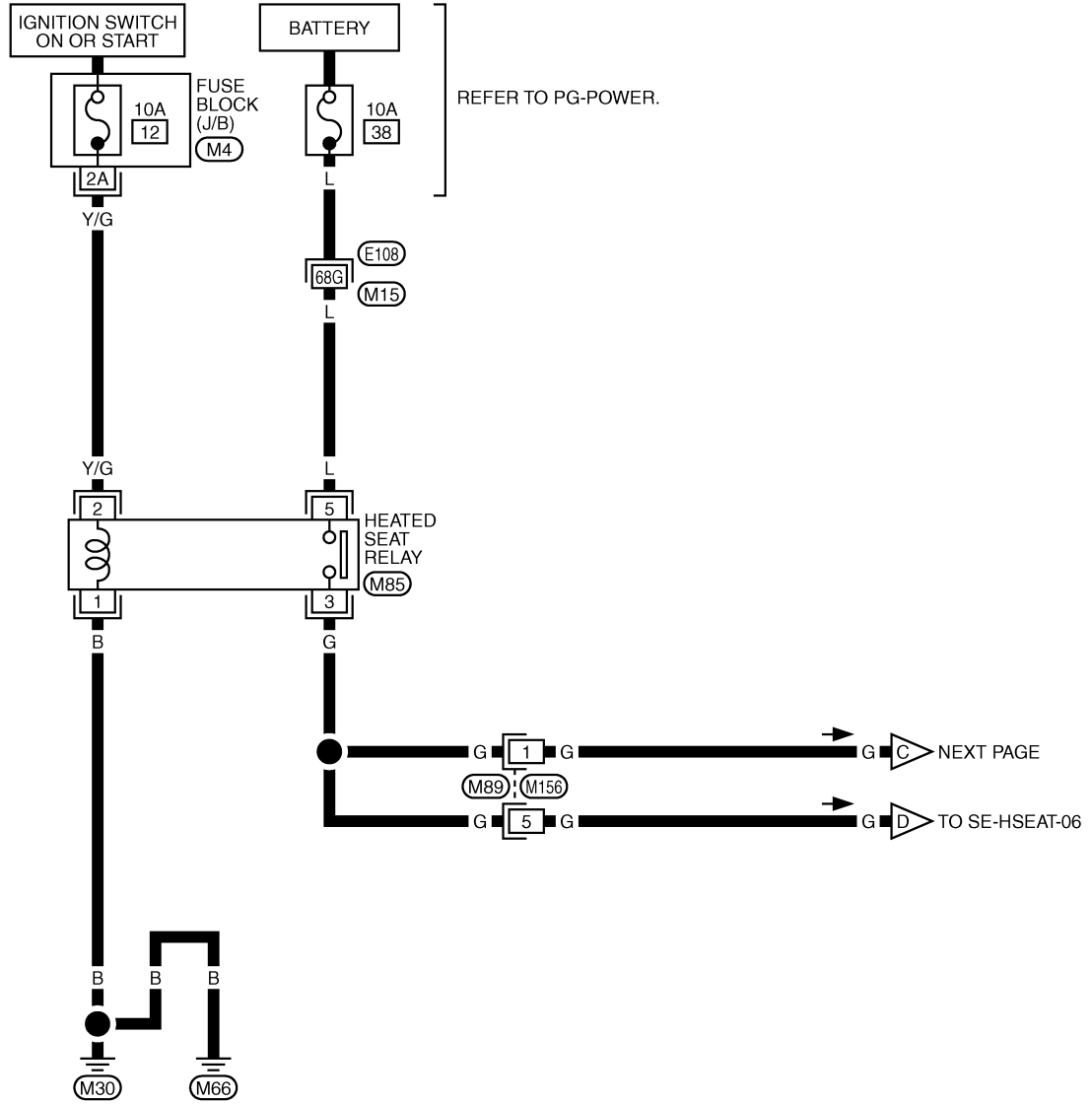

A
B
C
D
E
F
G
H
SE
J
K
L
M

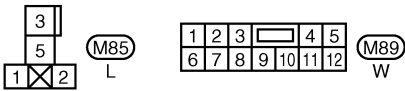

REFER TO THE FOLLOWING.
 (E108) -SUPER MULTIPLE JUNCTION (SMJ)
 (M4) -FUSE BLOCK-JUNCTION BOX (J/B)

TIWT0472E

HEATED SEAT

SE-HSEAT-05

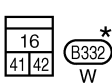
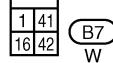
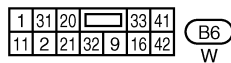
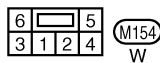
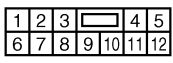
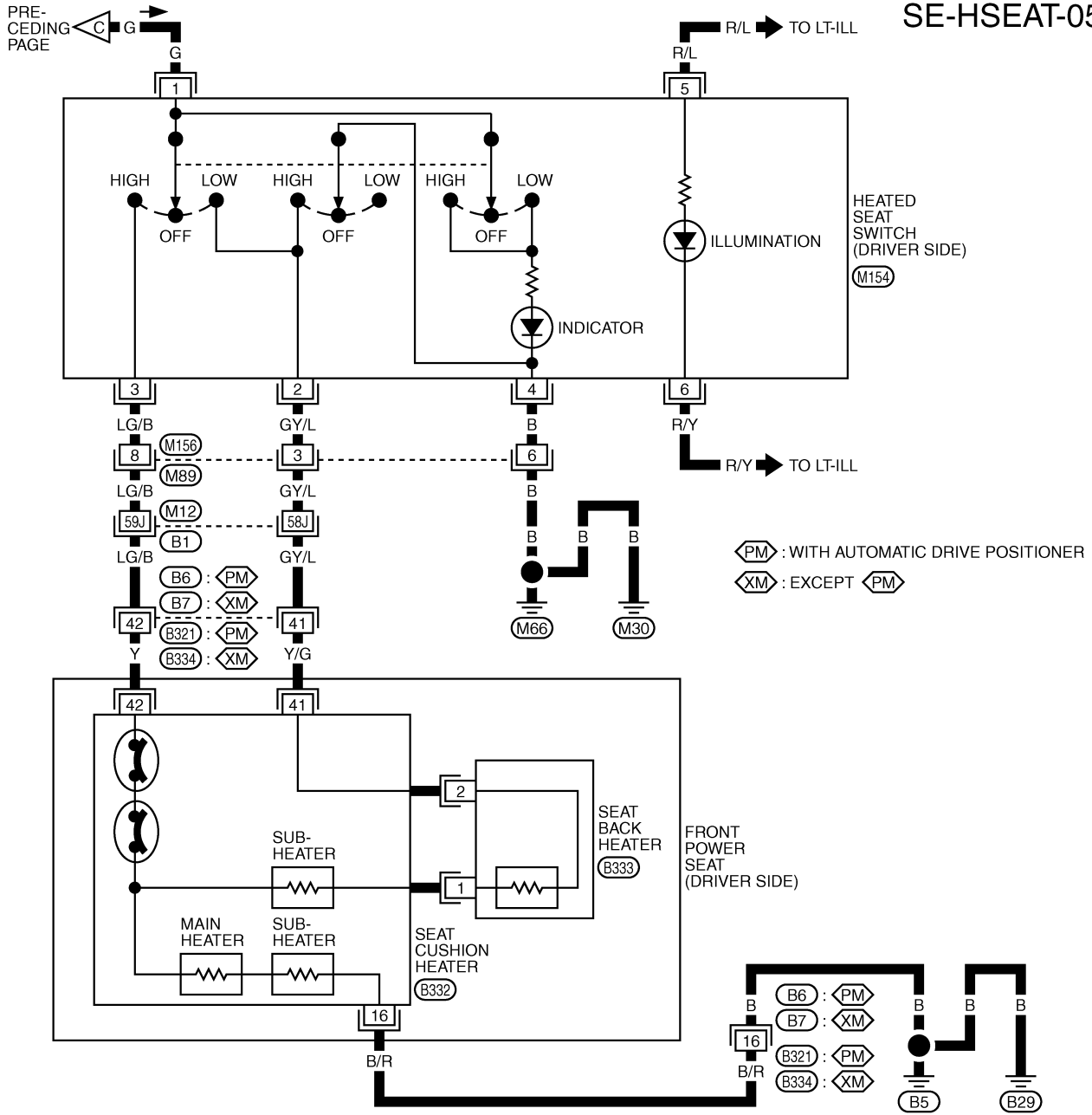

*: THIS CONNECTOR IS NOT SHOWN IN "HARNES LAYOUT", PG SECTION.

REFER TO THE FOLLOWING.

(B1) -SUPER MULTIPLE JUNCTION (SMJ)

TIWT0923E

HEATED SEAT

SE-HSEAT-06

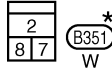
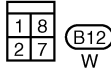
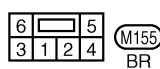
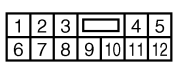
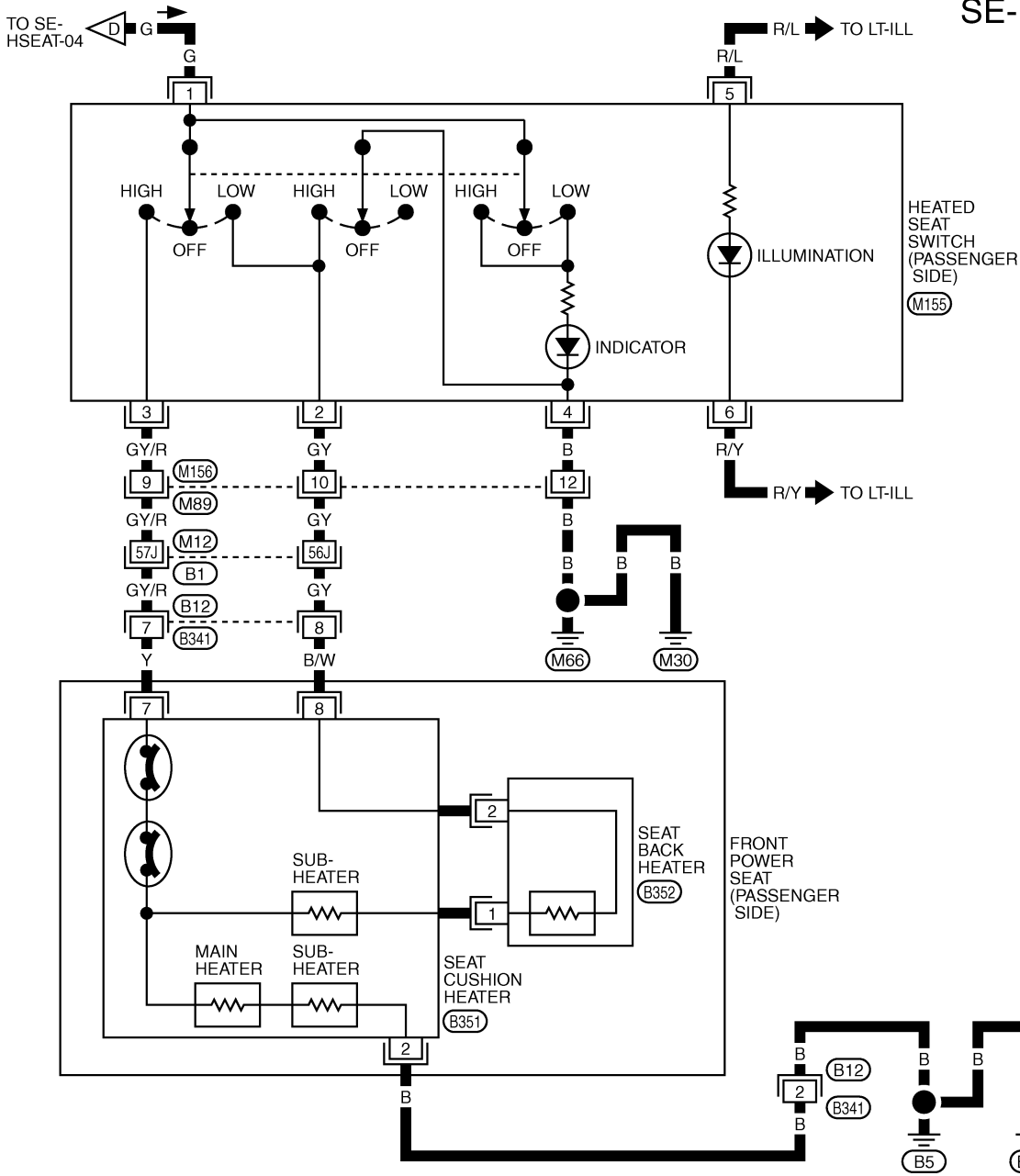

REFER TO THE FOLLOWING.
(B1) -SUPER MULTIPLE JUNCTION (SMJ)

*: THIS CONNECTOR IS NOT SHOWN IN "HARNESS LAYOUT", PG SECTION.

TIWT0474E

FRONT SEAT

PFP:87000

AIS000AK

FRONT SEAT

Removal and Installation

Manual seat

SEC. 870

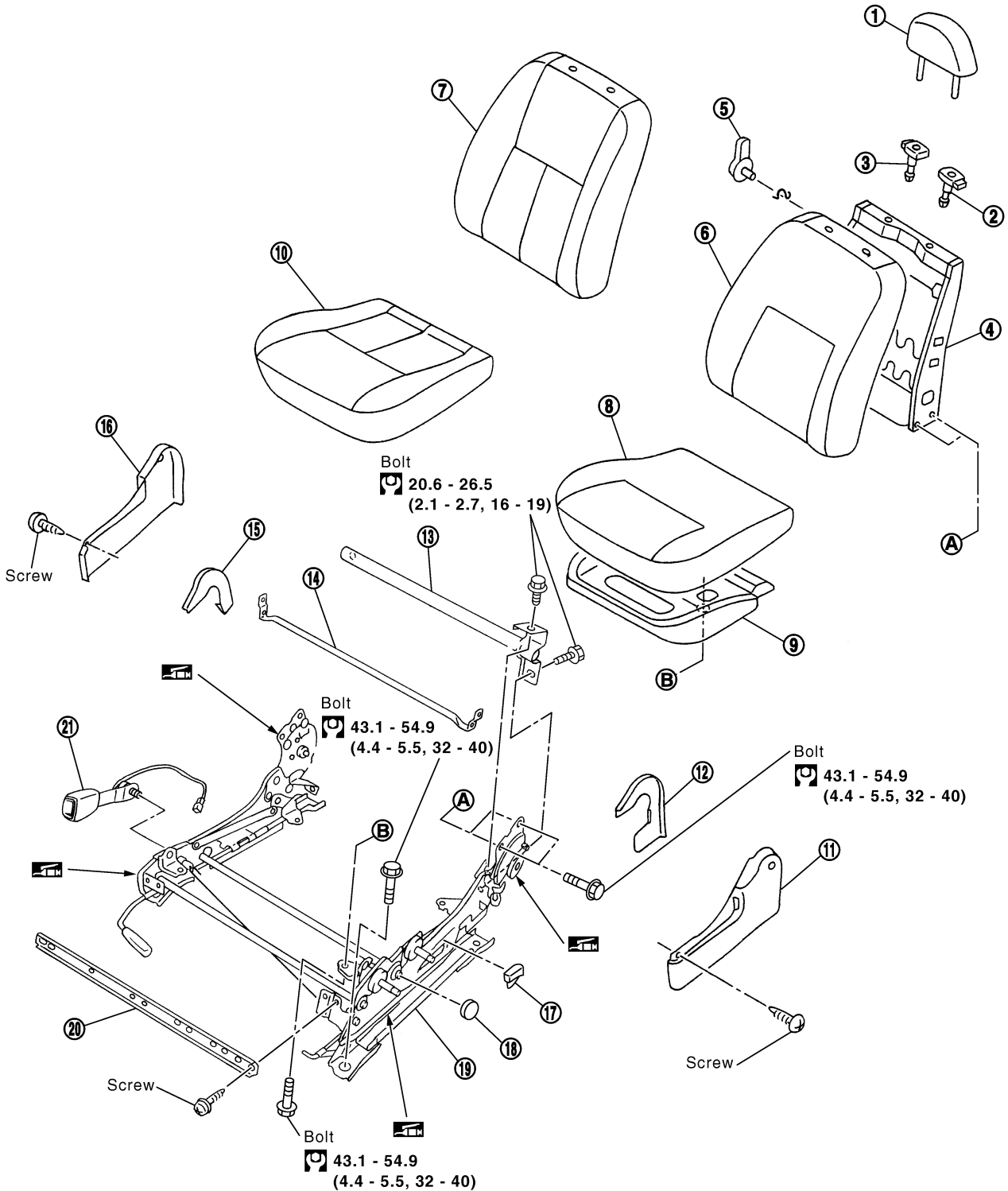

: Apply body grease.

: N·m (kg·m, ft·lb)

PIIA9995E

FRONT SEAT

- | | | |
|---------------------------------|----------------------------------|---------------------------------|
| 1. Headrest | 2. Headrest holder (locked) | 3. Headrest holder (free) |
| 4. Seatback frame | 5. Lumber support lever knob | 6. Seatback pad |
| 7. Seatback trim | 8. Seat cushion pad | 9. Seat cushion frame |
| 10. Seat cushion trim | 11. Seat cushion outer finisher | 12. Reclining device cover (LH) |
| 13. Sliding rail bracket (rear) | 14. Reclining device rod | 15. Reclining device cover (RH) |
| 16. Seat cushion inner finisher | 17. Reclining device lever knob | 18. Lifter dial |
| 19. Lifter base assembly | 20. Sliding rail bracket (front) | 21. Seat belt buckle |

A

B

C

D

E

F

G

H

SE

J

K

L

M

FRONT SEAT

Power seat

SEC. 870

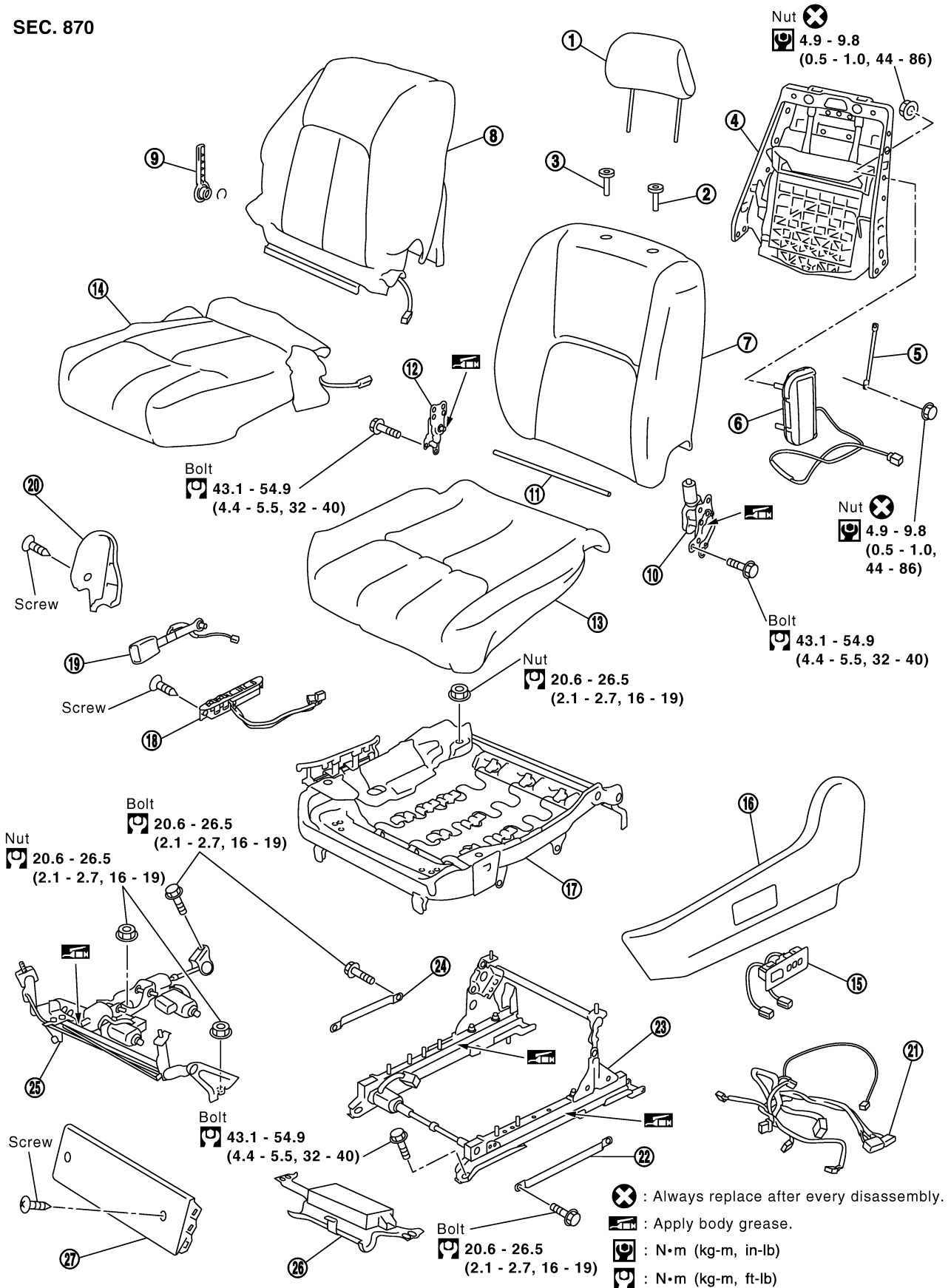

PIIA9996E

- 1. Headrest
- 4. Seatback frame

- 2. Headrest holder (locked)
- 5. Inner cloth stay

- 3. Headrest holder (free)
- 6. Driver side air bag module

FRONT SEAT

- | | | |
|--|---------------------------------------|---------------------------------|
| 7. Seatback pad | 8. Seatback trim | 9. Lumber support lever knob |
| 10. Reclining device (LH) | 11. Reclining device rod | 12. Reclining device (RH) |
| 13. Seat cushion pad | 14. Seat cushion trim | 15. Seat memory switch |
| 16. Seat cushion outer finisher | 17. Seat cushion frame | 18. Power seat switch |
| 19. Seat belt buckle | 20. Seat cushion inner finisher | 21. Driver power seat harness |
| 22. Seat cushion rod (LH) | 23. Seat lifter link slide assembly | 24. Seat cushion rod (RH) |
| 25. Seat lifter link motor unit assembly | 26. Driver seat control unit assembly | 27. Seat cushion front finisher |

REMOVAL

When removing or installing the seat trim, carefully handle it to keep dirt out and avoid damage.

CAUTION:

- Before removing the front seat, turn the ignition switch off, disconnect both battery cables and wait and least 3 minutes.
 - When checking the power seat circuit for continuity using a circuit tester, do not confuse its connector with the side air bag module connector. Such an error may cause the air bag to deploy.
 - Do not drop, tilt, or bump the side air bag module installing in the seat. Always handle it with care.
1. Remove the front leg cover and rear leg cover (LH/RH).

NOTE:

- Slide the seat backward, and disconnect the front tabs on the front leg cover. Then move the cover toward the rear of the vehicle, and pull up to remove.
- Slide the seat forward, then disengage the tabs on the front RH/LH of the rear leg cover and tabs engaged into the rail. Then pull the cover toward the rear of the vehicle.

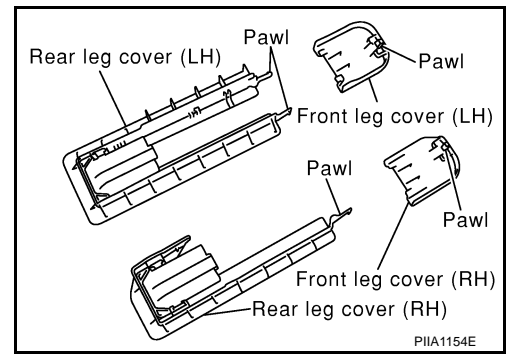

2. Slide the seat until the body mounting bolts are visible and a tool can be inserted.

NOTE:

When disassembling the driver seat after removal, set the front/rear cushion lifter to the top position.

3. Remove the body mounting bolts.
4. Disconnect both battery cables.
5. Remove the harness connector for the side air bag module.
6. Remove the power seat harness connector and vehicle harness fixing clip out of the vehicle.

NOTE:

When removing and installing, using shop clothes, protect the parts from damage where it may interfere with others.

INSTALLATION

Install in the reverse order of removal.

NOTE:

Be sure to insert the rear end tab of the rear leg cover under the rail.

A
B
C
D
E
F
G
H
SE
J
K
L
M

FRONT SEAT

AIS000AL

Disassembly and Assembly SEATBACK TRIM AND PAD

Disassembly

1. Open zipper on back of seatback, and remove retainer from seatback frame.

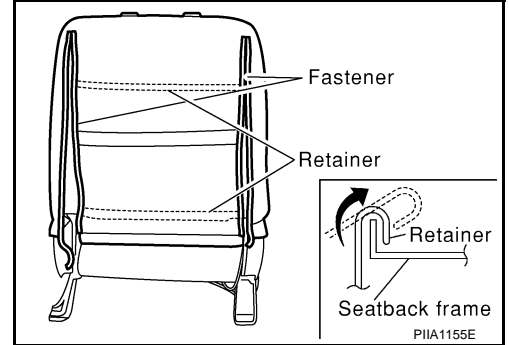

2. Pull snap ring upward, and remove lumbar support lever knob from seatback frame.

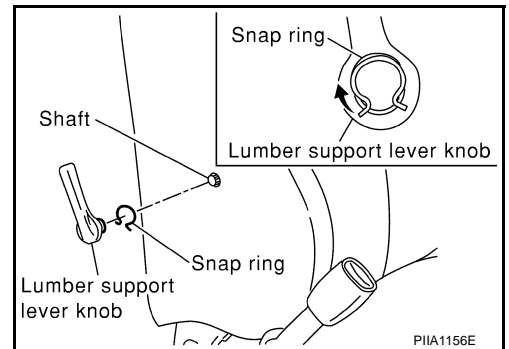

3. Remove the stay securing the inner cloth.

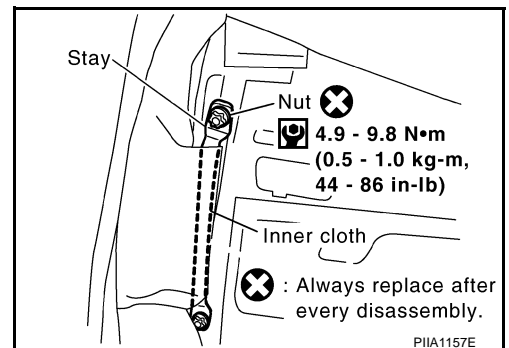

4. Remove headrest holder (with active headrest).
From the back of the seatback, press the headrest holder tab of the stay pipe hole to disengage. Then pull the headrest holder up to remove.

NOTE:

Before installing the headrest holder, check its orientation (front/rear and right/left).

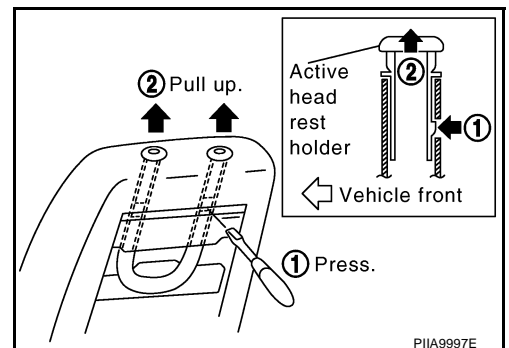

FRONT SEAT

5. Remove headrest holder (without active headrest). Squeeze and pull up headrest holder tabs to remove from seatback frame.

NOTE:

Before installing the headrest holder, check its orientation (front/rear and right/left).

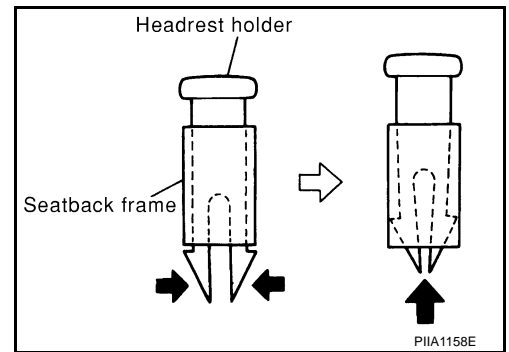

6. Remove the seat heater harness connector. After removing the seatback trim and pad, remove the hog ring to separate the trim, pad, and seatback heater unit.

Assembly

Assemble in the reverse order of disassembly.

REMOVAL OF SEATBACK ASSEMBLY

1. After completing the steps 1 and 2 of "Seatback trim and pad", remove the harness connectors for the reclining motor and lumbar support motor (driver seat only).
2. Pull out the harness connector for the side air bag from the seat cushion.
3. Remove the reclining device mounting bolts on the seatback frame, and remove the seatback assembly.

NOTE:

When assembling the seatback frame, make sure that the reclining device are locked on both sides, and be sure to temporarily tighten the bolts, then tighten them finally.

INSTALLATION OF SEATBACK ASSEMBLY

Install in the reverse order of removal.

SEAT CUSHION TRIM AND PAD (POWER SEAT)

Disassembly

1. Remove the seat cushion front finisher and seat cushion outer finisher.

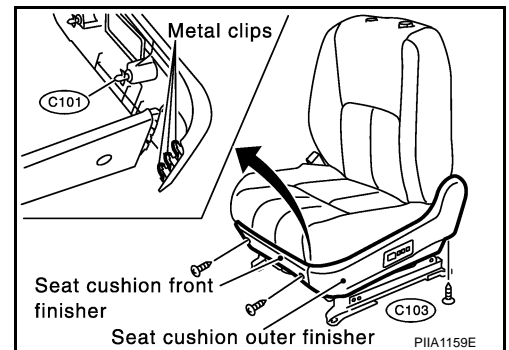

2. Remove the power seat switch assembly.

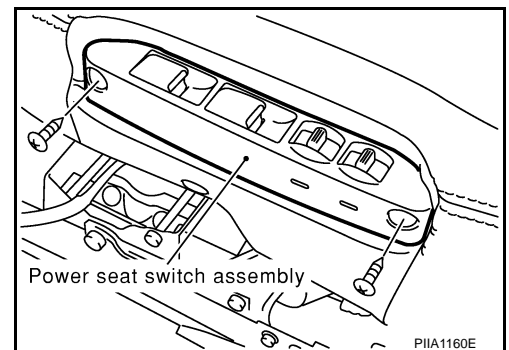

3. Remove the retainer on the seat cushion frame, then remove the harness connector for the seat heater.
4. After removing the seat cushion trim and pad, remove the hog rings to separate the trim and pad and the seat cushion heater unit.

FRONT SEAT

Assembly

Assemble in the reverse order of disassembly.

SEAT CUSHION TRIM AND PAD (MANUAL SEAT)

Disassembly

1. Pull up tabs of reclining lever inside. Slide knob forward to remove.

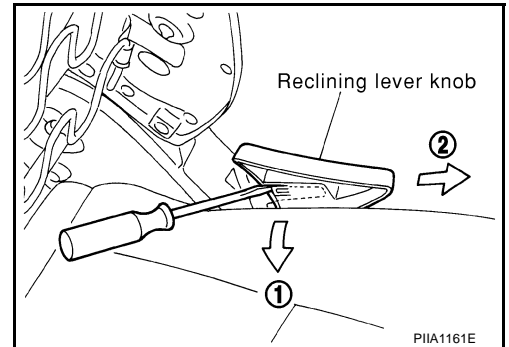

2. Hang snap ring on wire, and pull it up to remove. Remove lifter dial.

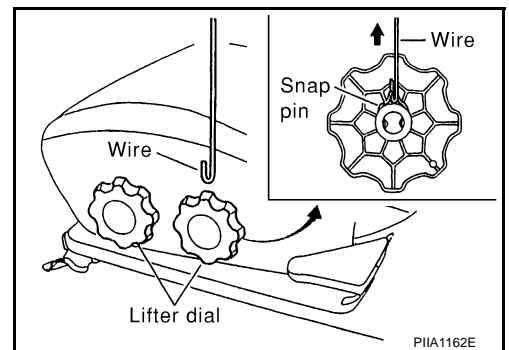

3. Remove mounting bolts by accessing them from back of seat cushion.

NOTE:

When installing bolts, ensure that locks on both sides of slide are engaged. First temporarily tighten them, and then finally tighten.

4. Remove retainer from back of cushion.
5. Pull off trim and remove hog rings.

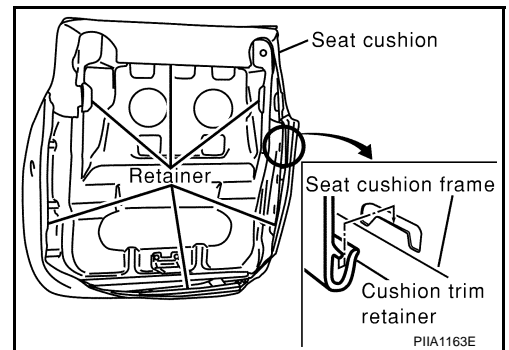

Assembly

Assemble in the reverse order of disassembly.

REAR SEAT

REAR SEAT

PFP:88300

Removal and Installation

AI50008I

Standard seat

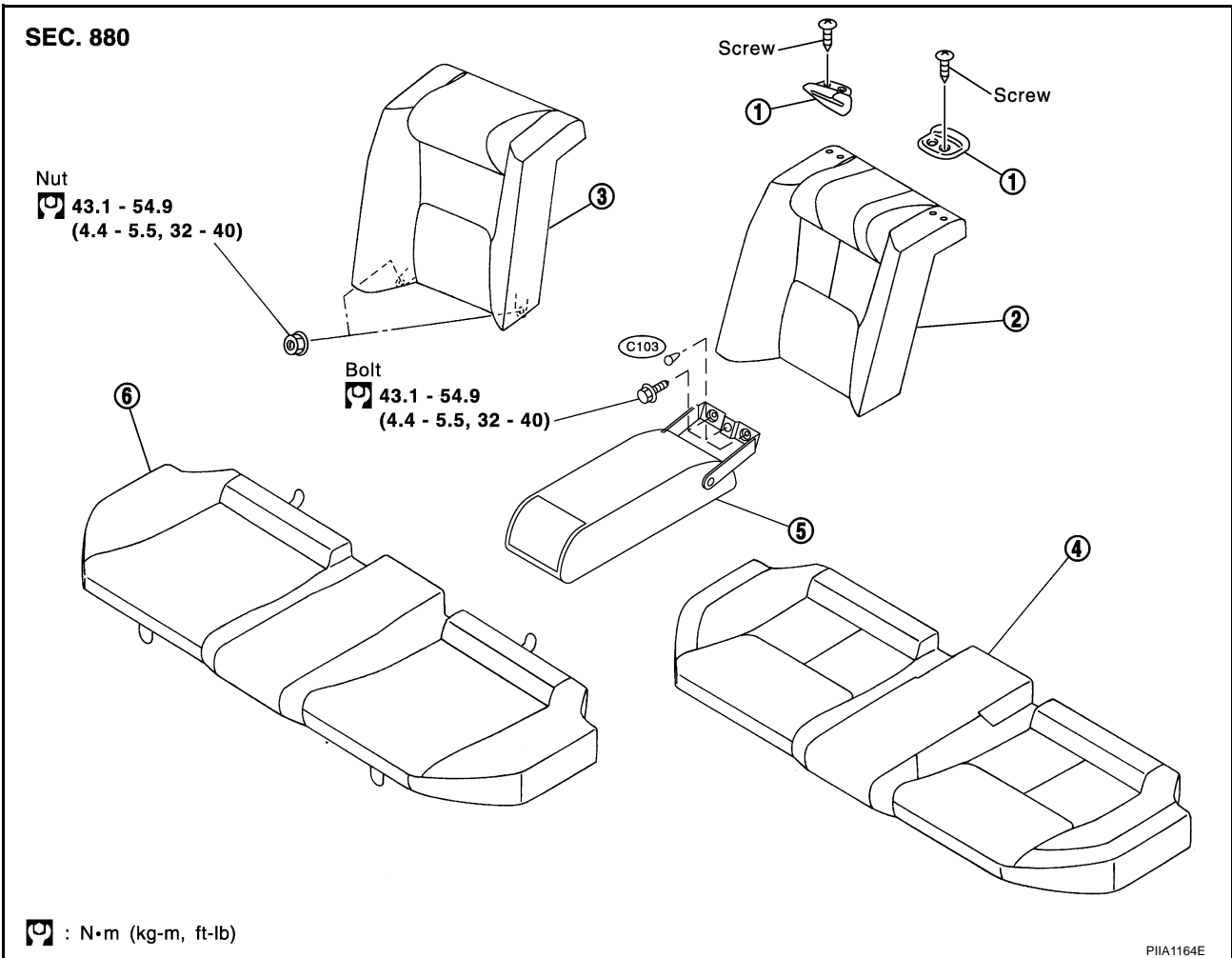

- 1. Seat belt guide
- 2. Seatback trim
- 3. Seatback pad
- 4. Seat cushion trim
- 5. Armrest assembly
- 6. Seat cushion pad

A
B
C
D
E
F
G
H
SE
J
K
L
M

REAR SEAT

Reclining seat

SEC. 880

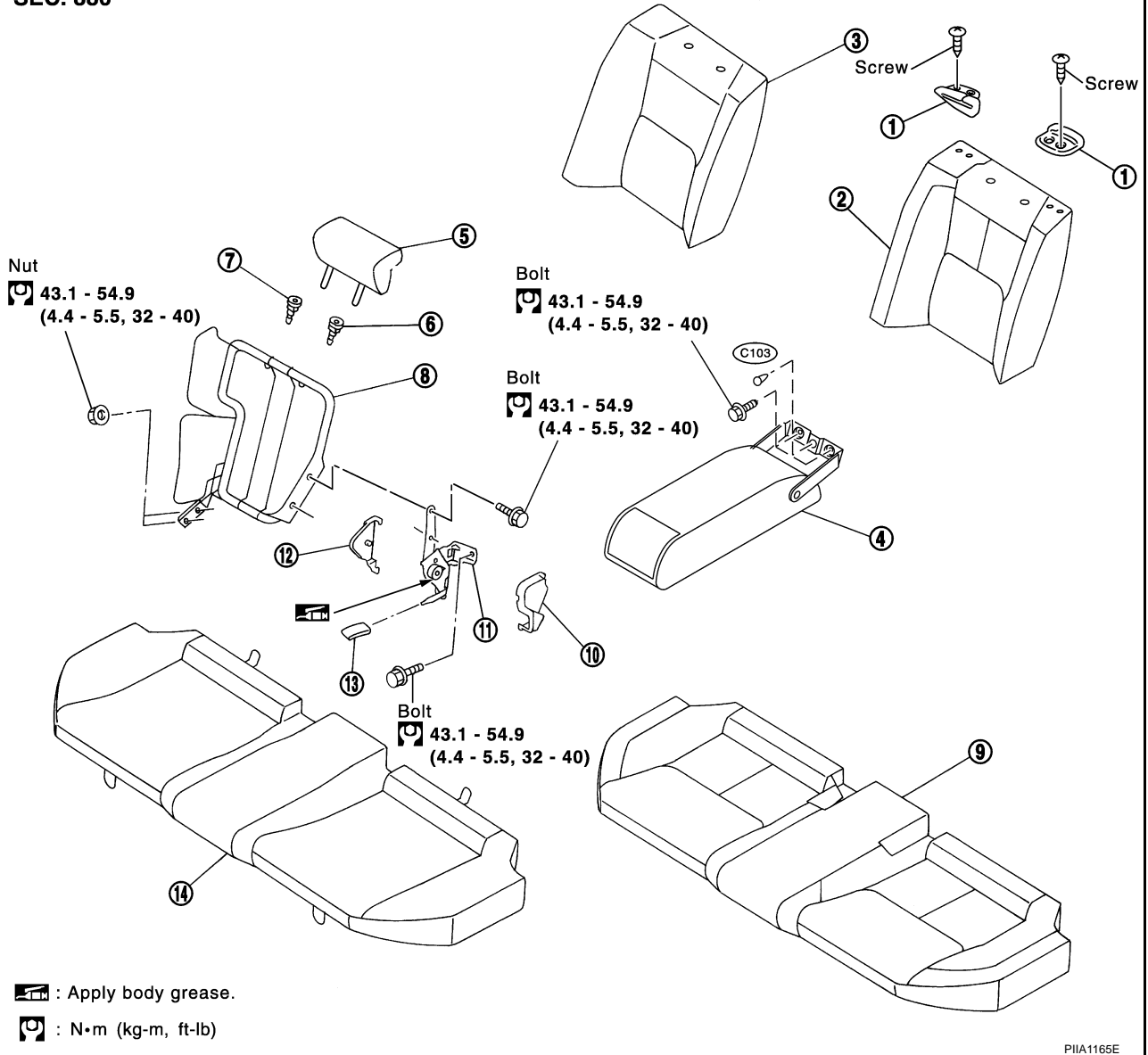

PIIA1165E

- | | | |
|---------------------------------|----------------------|-----------------------------|
| 1. Seat belt guide | 2. Seatback trim | 3. Seatback pad |
| 4. Armrest assembly | 5. Headrest | 6. Headrest holder (locked) |
| 7. Headrest holder (free) | 8. Seatback frame | 9. Seat cushion trim |
| 10. Reclining device inner | 11. Reclining device | 12. Reclining device outer |
| 13. Reclining device lever knob | 14. Seat cushion pad | |

REAR SEAT

Armrest assembly

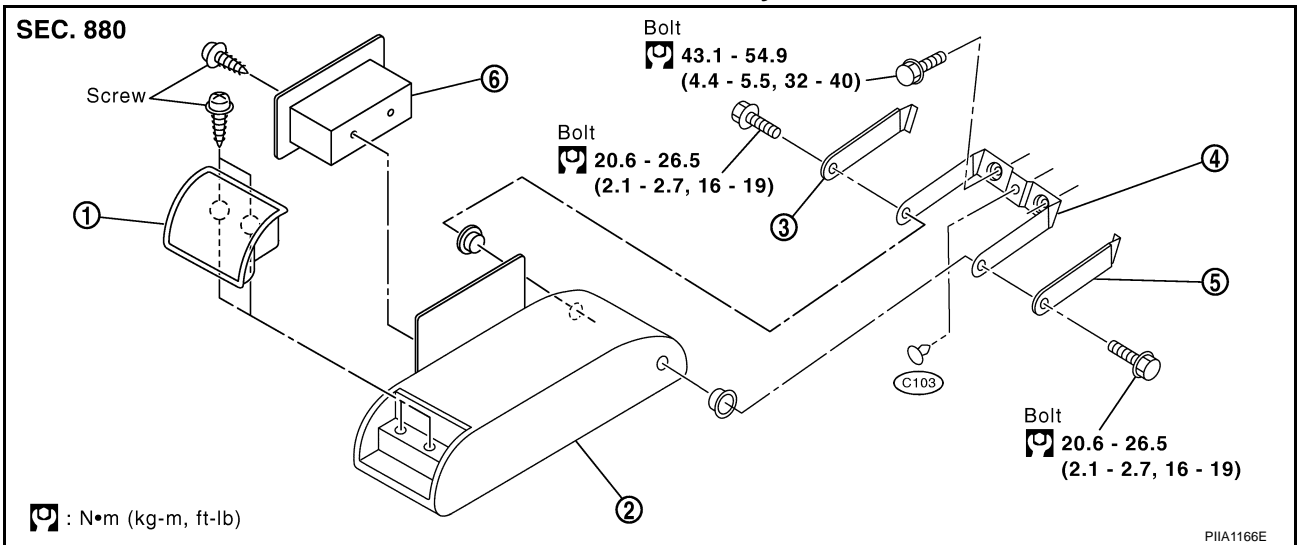

- | | | |
|--------------------|-------------------------------------|-------------------------------------|
| 1. Cup holder | 2. Armrest trim and pad | 3. Armrest bracket outer cover (RH) |
| 4. Armrest bracket | 5. Armrest bracket outer cover (LH) | 6. Armrest side console |

Rear seat center back finisher

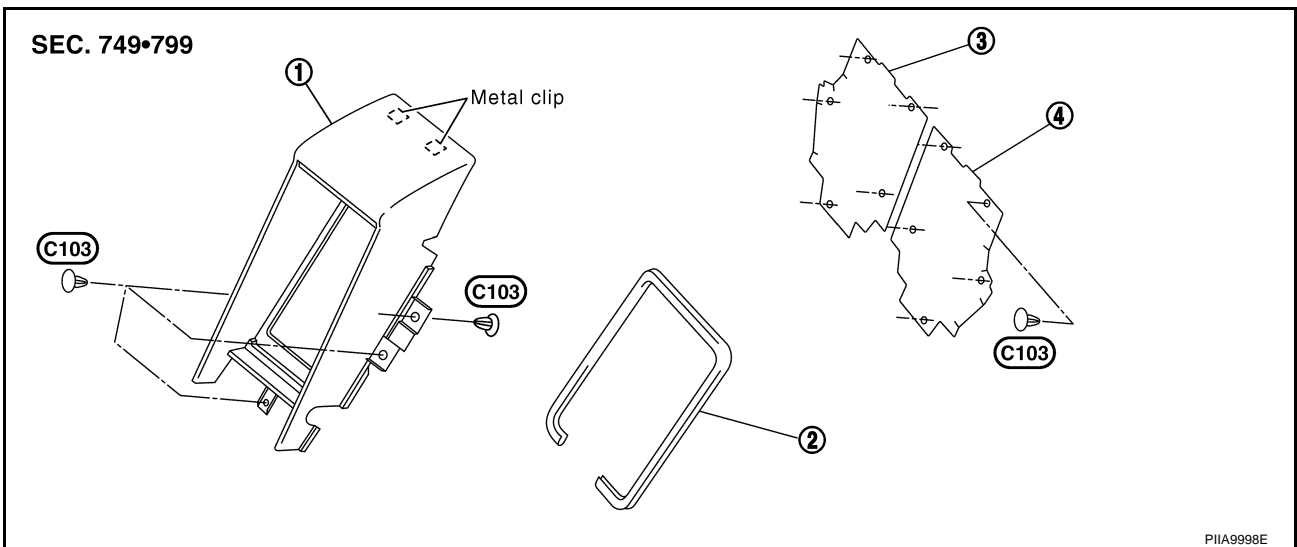

- | | | |
|-----------------------------------|---------|----------------------------|
| 1. Rear seat center back finisher | 2. Welt | 3. Welt rear seatback (RH) |
| 4. Welt rear seatback (LH) | | |

REMOVAL

1. Pull the lock at the front bottom of the seat cushion forward (1 for each side), and pull the seat cushion upward to release the wire from the plastic hook, then pull the seat cushion forward to remove.

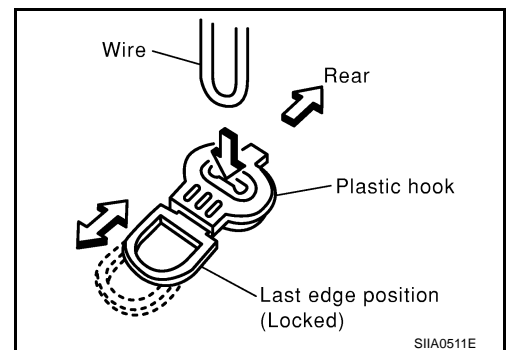

INSTALLATION

Install in the reverse order of removal.

A
B
C
D
E
F
G
H
SE
J
K
L
M

REAR SEAT
